



SMF系列双筒中压过滤器

SMF DUPLEX MIDDLE PRESSURE LINE FILTER SERIES

(一) 简介

该过滤器由两只单筒过滤器，两只单向阀，换向阀，发讯器等组成，它可在系统在不停机的状况下更换滤芯，适用于连续工作的中低压液压系统。

当其中一只过滤筒的滤芯在工作过程中堵塞至压差发讯器规定的压力值时，发讯器动作，更换滤芯时，只要旋转换向阀手柄到另一位置后，备用的过滤筒开始工作，旋开已堵塞的过滤筒放油螺塞放完油后，再旋下外壳，即可更换滤芯。注：1 堵塞后应及时更换滤芯，以免由于滤芯压差继续上升导致滤芯破损，造成再污染系统。2 换向阀手柄必须到位，需更换滤芯侧过滤筒，允许少量内泄漏。3 换向后已堵塞的滤芯应及时更换新滤芯，以备下次使用。

INTRODUCTION

The SMF series filter is composed of two single bowl filters, two check valves, directional valve and indicator. It fit the medium and low pressure hydraulic system. The feature of this filter allows continuous operation when changing clogged element. When the element is clogged by contaminant, the indicator will give signals showing that the element should be changed. At this time turn the directional valve, the other filter will begin to work and then change the clogged element. Attention: 1.change the clogged element in time lest the clogged element dirt the hydraulic system.

2.make sure every time turning the directional valve, it should be turned to the right position.

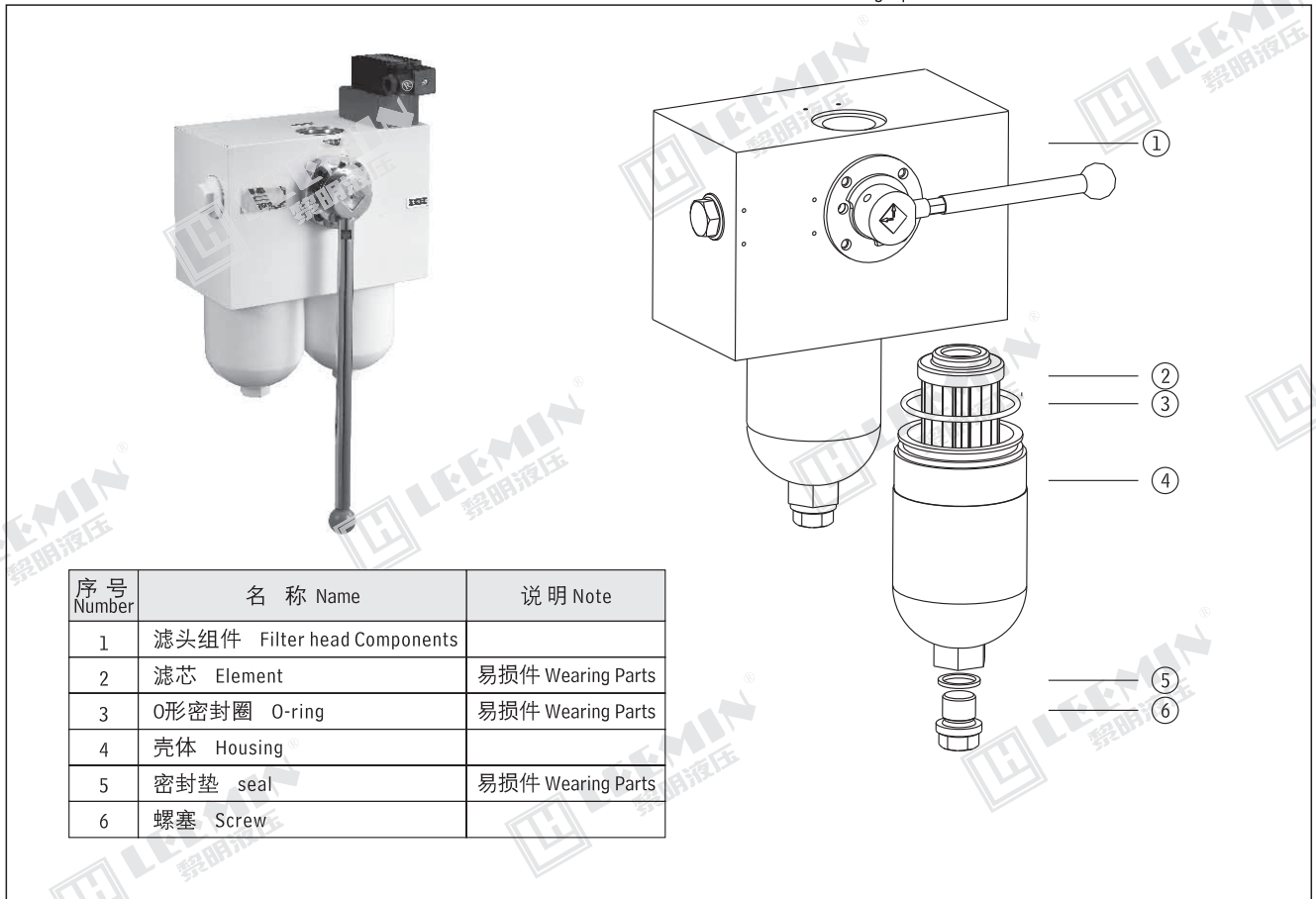

(二)型号说明 MODEL CODE

双筒中压过滤器 Duplex Middle Pressure Line Filter	SMF · □-D□ × □C	E:电子模拟发讯器 Electronic analog indicator C:带CMS压差发讯器 With CMS indicator 省略: 不带发讯器 Omif if without indicator
BH: 介质为水-乙二醇 Water-glycol 省略: 介质为一般液压油 Omif if use hydraulic Oil		过滤精度 Filtration connectoin:(μ m)
压力等级 Pressure class:10 MPa		公称流量 Flow rate(L/min)

注：用户订购过滤器需配【电子模拟发讯器】时，请与我公司技术部联系。

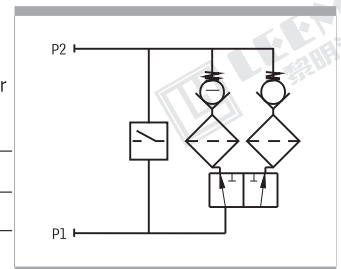



(三)技术参数 TECHNICAL DATA

型号 Model	公称流量 Flow rate (L/min)	过滤精度 Filtr. (μ m)	公称压力 Press. (MPa)	通径 Dia. (mm)	压力损失 Pressure loss(MPa)		发讯装置 Indicator	重量 Weight (Kg)	连接方式 Connect	滤芯型号 Model of element
					Initial	Max.				
SMF-D30X*	30	5	10	10	≤ 0.08	0.5	24V/48W 220V/50W		螺纹 Threaded	LH0060D*BN3HC
SMF-D100X*	100	20		25						LH0160D*BN3HC

注: *为过滤精度。若使用介质为水—乙二醇, 使用压力10MPa, 公称流量100L/min, 过滤精度10 μ m, 带发讯器。则过滤器型号为SMF·BH-H100 \times 10C, 滤芯型号为LH0160D010BN3HC.BH

Note: *is represents filtration. If the filter fluid is water-glycol, usage pressure 10MPa, flow rate 100L/min, filtration accuracy 10 μ m and the filter equipped with indicator. The model of the filter is SMF·BH-H100 \times 10C, the model of element is LH0160D010BN3HC.BH

(四)安装尺寸 MOUNTING SIZE

型号 Model	H	H1	H2	L	L1	L2	A	a	B	b	M	d	h	c	e	L3
SMF-D30X*	273	203	52	180	116	66	118	80	170	145	M27X2	M8	10	12.5	19	41
SMF-D100X*	362	292	80	246	163	93.5	166	135	230	190	M33X2	M10	15	20	16	60

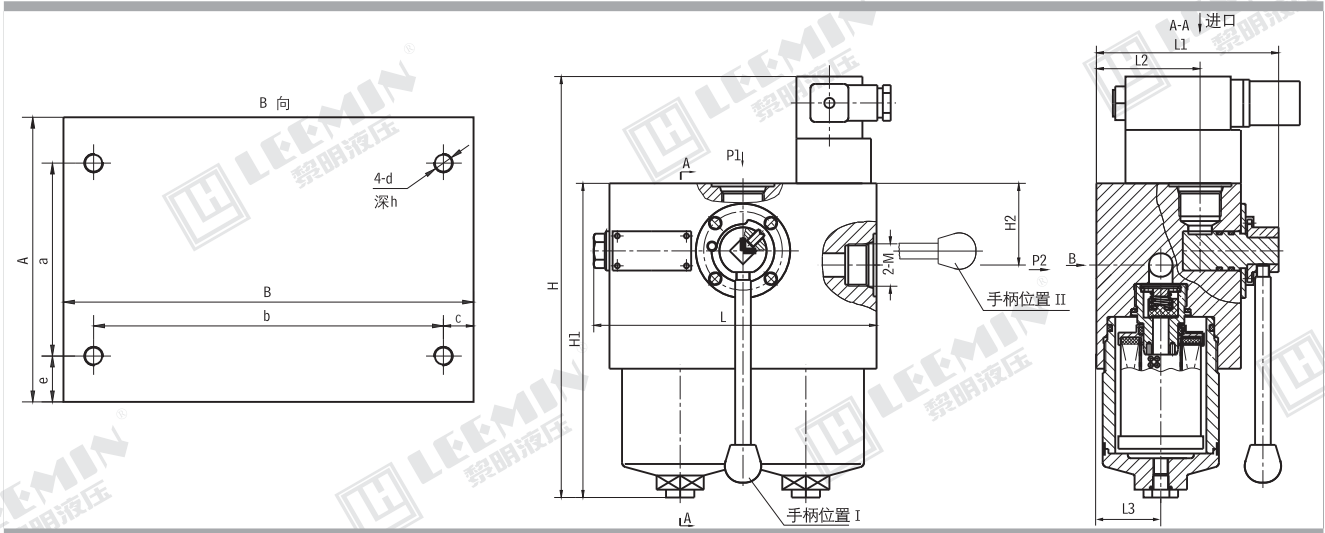

SLLF系列双筒润滑过滤器

SLLF DUPLEX LUBRICATION FILTER SERIES

(一)简介

SLLF双筒过滤器是由两只单筒过滤器及二位六通换向阀组成, 结构简单、使用方便, 并带有旁通阀及滤芯污染堵塞发讯器, 以达到保护系统安全的目的。

本过滤器配有永久磁铁, 可滤除油液中1微米以上的铁磁性颗粒。

它的特点是当一只过滤器滤芯堵塞需更换或清洗时, 不需要停止主机工作, 只要打开压力平衡阀并转动换向的滤芯, 滤芯为组合型, 使清洗更换滤芯更方便。需更换滤芯侧过滤筒, 允许少量内泄漏。

本过滤器适用于重型机械, 矿山机械, 冶金机械等稀油润滑系统。

INTRODUCTION

SLLF series filter is composed of two single bowl filters and one 2-position 6 way directional valve. It is simple in construction and easy to use. There is a bypass valve and two contamination indicators in it, for protecting the lubricating system safety.

The feature of this filter allows continuous operation even if the clogged element needs replacing for a clean one. After opening the balance valve and then turning the directional valve, the other filter will begin to work in the lubricating system; the clogged element should be changed at that time. This series filter is used in lubricating systems of heavy duty, mining and metallurgical machines.