



SGF系列双筒高压过滤器 SGF DUPLEX HIGH PRESSURE LINE FILTER SERIES

(一) 简介

该过滤器安装在油泵出油口高压管路上，用以保护控制元件及执行机构。特别是自动控制系统中，高精度的伺服元件及柱塞元件，可有效地防止污染避免故障，延长元件使用寿命。

该过滤器由两只单筒过滤器，换向阀、旁通阀、发讯器等组成，能使系统在不停机状况下更换滤芯，适用于连续工作的液压系统。

当其中一只过滤器的滤芯堵塞至压差发讯器压力指示值为0.5MPa时、发讯器发讯、这时必须更换滤芯。只要转动换向阀、另一只备用过滤器即刻工作，这时只需旋开螺塞放完油、再旋下外壳、就可更换已堵塞的滤芯。需更换滤芯侧过滤筒，允许少量内泄漏。

如因故未能及时更换滤芯压差继续升至旁通阀开启压力

0.6MPa时，旁通阀自动开启，以避免由于压力继续上升，滤芯破裂造成再污染，但用户必须在发讯器发讯时更换滤芯。

INTRODUCTION

The SGF series filter is composed of two single bowl filters, check valve, directional valve and indicator. It should be installed at outlet of the high-pressure line. The feature of this filter allows continuous operation even during replacing element, which is clogged by contaminant. When the pressure of the contaminant clogged element reaches to 0.5Mpa, the indicator gives signals showing that the element should be changed. At this time, turn the directional valve, let the other filter work, and change the clogged element. If the element can't be changed in time until the pressure reaches to 0.6Mpa, the by-pass valve will open automatically to keep the system safety.

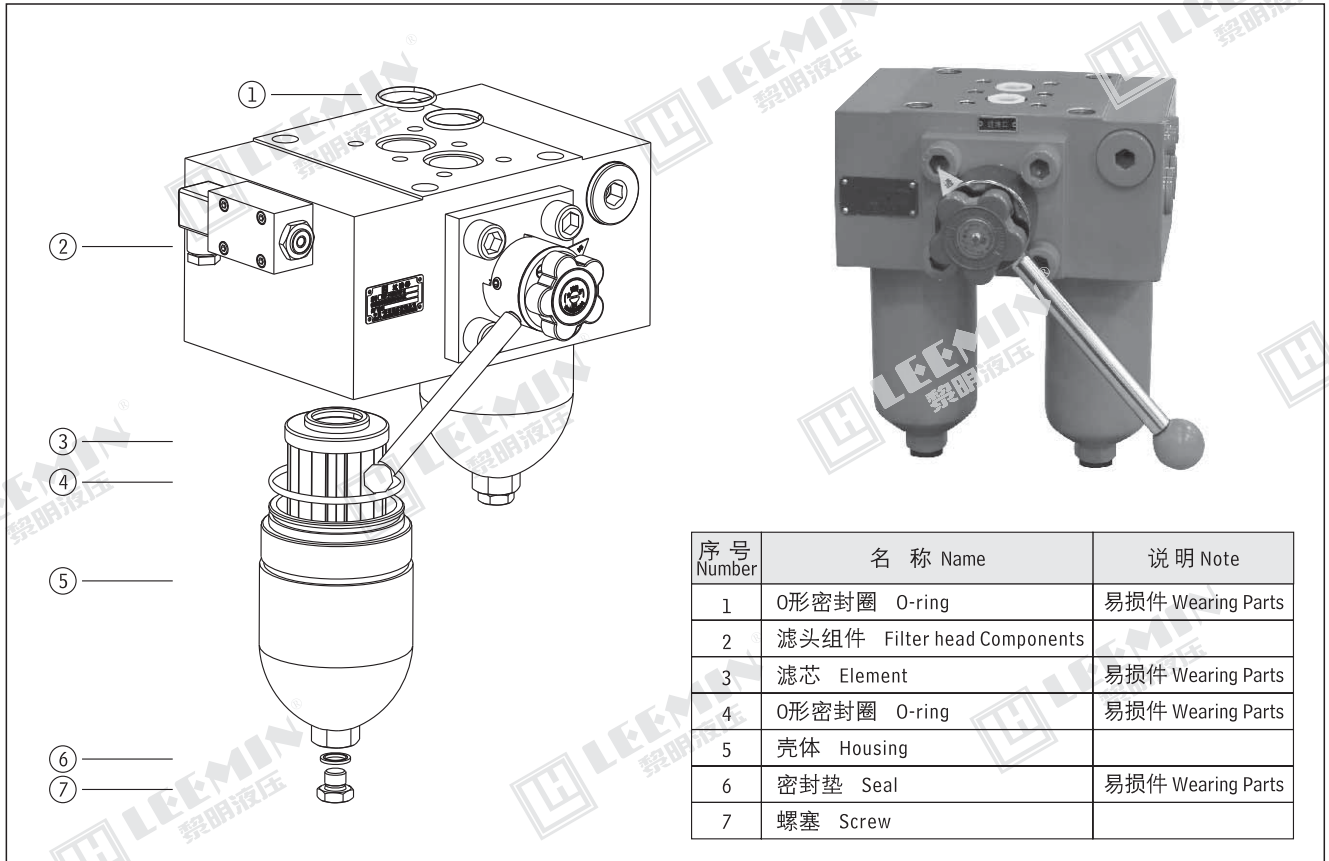

(二) 型号说明 MODEL CODE

SGF · □-H□ × □□-□

双筒高压过滤器 Duplex high pressure line filter

BH:介质为水-乙二醇 Water-glycol

省略:介质为一般液压油 Omif if use hydraulic oil

公称压力 Pressure class:32MPa

E:电子模拟发讯器 Electronic analog indicator

C:带CMS压差式发讯器 With CMS indicator

省略:不带发讯器 Omit if without indicator

F:为法兰连接 Flanged connection

过滤精度 Filtration connection:(μ m)

公称流量 Flow rate(L/min)

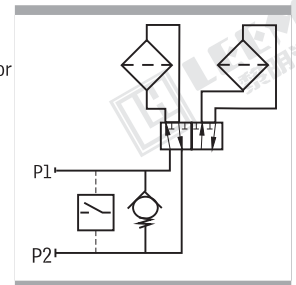

注:用户订购过滤器需配【电子模拟发讯器】时,请与我公司技术部联系。



(三) 技术参数 TECHNICAL DATA

型号 Model	公称流量 Flow rate (L/min)	过滤精度 Filtr. (μ m)	公称压力 Press. (MPa)	通径 Dia. (mm)	压力损失 Pressure loss(MPa)		发讯装置 Indicator		重量 Weight (Kg)	连接方式 Connect	滤芯型号 Model of element
					Initial	Max.	(V)	(A)			
SGF-H30 × *	30	3	32	20	≤0.08	0.5	12	2.5	法兰式 Flange	PLFX-30 × *	
SGF-H60 × *	60			20						LH0060D*BN3HC	
SGF-H110 × *	110			20						LH0110D*BN3HC	
SGF-H160 × *	160	32		24			2	LH0160D*BN3HC			
SGF-H240 × *	240							32		LH0240D*BN3HC	
SGF-H330 × *	330	10		50			36	1.5		LH0330D*BN3HC	
SGF-H500 × *	500		50	LH0500D*BN3HC							
SGF-H660 × *	660	20	50	220	0.25	LH0660D*BN3HC					

注：*为过滤精度。若使用介质为水—乙二醇，使用压力32MPa，公称流量160L/min，过滤精度10 μ m，带发讯器。则过滤器型号为SGF·BH-H160×10C，滤芯型号为LH0160D010BN3HC

Note: *is represents filtration. If the filter fluid is water-glycol, usage pressure 32MPa、flower rate 160L/min、filtration accuracy 10 μ m and the filter equipped with indicator. The model of the filter is SGF·BH-H160×10C, the model of element is LH0160D010BN3HC

(四) 安装外形尺寸 MOUNTING SIZE

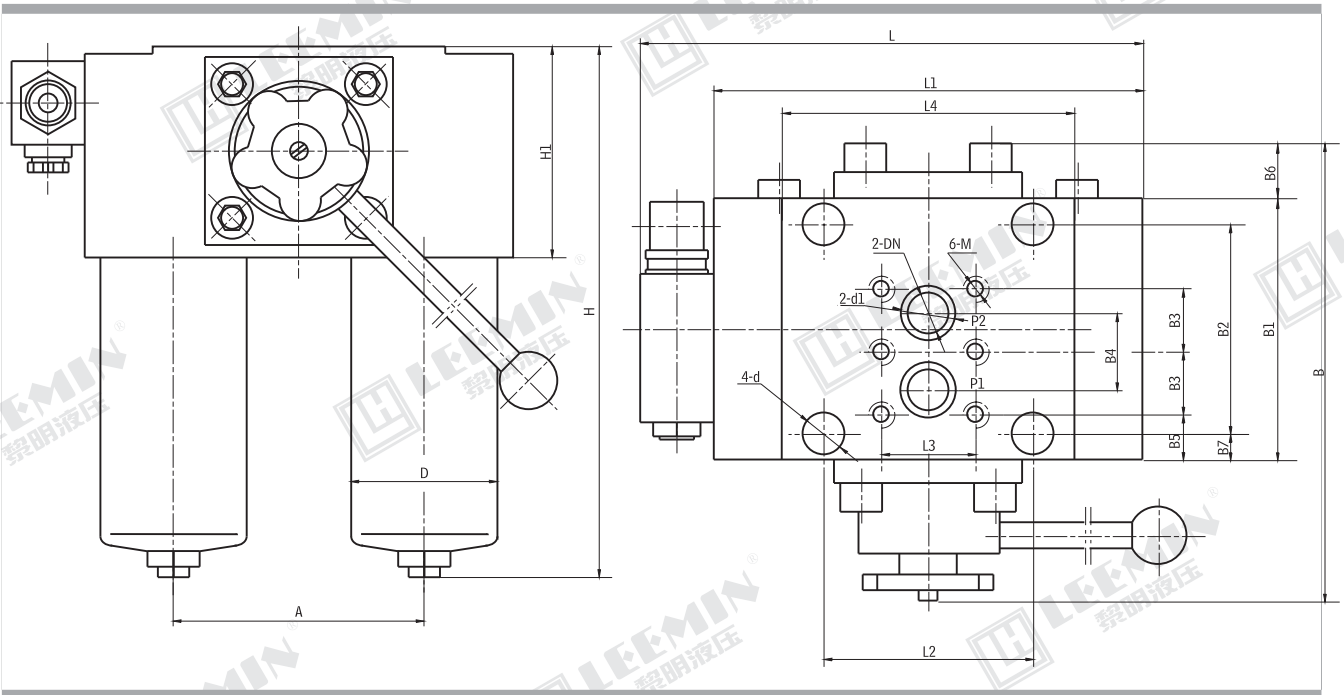

单位 Unit:mm

型号 Model	H	H1	B	B1	B2	B3	B4	B5	B6	B7	A	L	L1	L2	L3	L4	D	DN	d1	d	M
SGF-H30 × *	180	106	242	136	106	32	36	28	30	15	120	246	210	104	46	134	73	20	28	17.5	M12
SGF-H60 × *	196	106	242	136	106	32	36	28	30	15	120	246	210	104	46	134	73	20	28	17.5	M12
SGF-H110 × *	265	106	242	136	106	32	36	28	30	15	120	246	210	104	46	134	73	20	28	17.5	M12
SGF-H160 × *	251	129	278	172	142	45	48	29	30	15	140	296	260	110	52	140	102	32	40	17.5	M12
SGF-H240 × *	309	129	278	172	142	45	48	29	30	15	140	296	260	110	52	140	102	32	40	17.5	M12
SGF-H330 × *	330	152	377	230	190	57	66	41	48	20	210	414	380	160	85	200	146	50	60	26	M20
SGF-H500 × *	423	152	377	230	190	57	66	41	48	20	210	414	380	160	85	200	146	50	60	26	M20
SGF-H660 × *	497	152	377	230	190	57	66	41	48	20	210	414	380	160	85	200	146	50	60	26	M20