



RFA 系列微型直回式回油过滤器

RFA TANK MOUNTED MINI-TYPE RETURN FILTER SERIES

(一)简介

本过滤器用于液压系统回油精过滤，滤除液压系统中元件磨损产生的金属颗粒以及密封件的橡胶杂质等污染物，使流回油箱的油液保持清洁。

本过滤器安装在油箱顶部，筒体部分浸入油箱内，并设置旁通阀、扩散器、滤芯污染堵塞发讯器等装置。具有结构紧凑、安装方便、通油能力大、压力损失小、更换滤芯方便等特点。

(二)性能与特点

1.安装连接方便，简化系统管路

本过滤器直接安装在油箱盖板上，过滤器滤头露在油箱外，回油筒体浸入油箱内，进口口设有管式与法兰式连接，从而简化了系统管路，使系统布置较为紧凑，安装连接更方便。

2.设置滤芯污染发讯器，油路旁通阀，提高液压系统的可靠性：

当滤芯被污染物堵塞或系统液温过低，流量脉动等因素造成进油压力为0.35MPa时，发讯装置便发出讯号指示。应及时更换滤芯或提高油液温度。如此时不能马上停机处理这些故障时，设在滤芯下部的旁通阀自动开启工作(旁通阀开启压力为0.4MPa)，以保护过滤器及液压系统正常工作。

3.设计采用直回滤油，使更换滤芯或向油箱加油非常方便：

只需旋开过滤器滤盖(清洗盖)即可更换滤芯或向油箱加油，并在滤头设有2只M18×1.5油口，可在任何一方安装发讯器或系统中少量油液回流油箱过滤之用。

4.具有液流扩散器

扩散器设置在回油筒体底部，能使回油的介质平稳地流入油箱内，不易产生气泡，从而减少空气重新进入，并减弱已沉积的污染物骚动。

5.滤芯采用玻璃纤维过滤材质

具有过滤精度高，通油能力大，原始压力损失小，纳污量大等优点。其过滤精度以绝对过滤精度标定，过滤比 β_3 、5、10、20 \geq 200，过滤效率 $n\geq$ 99.5%，符合ISO标准。

INTRODUCTION

This kind of filter can be used in hydraulic system for fine filtration. It can be installed on the cover of the tank. The filter head should be out of the tank and the filter bowl should immerse in the oil. The inlet port has threaded and flanged connections. The filter has indicator and by pass valve. When the dirt accumulates in the filter element or the temperature of the system is too low, and the oil inlet pressure reaches 0.35MPa, the indicator will give signals showing that the filter element should be cleaned, changed or raise the temperature. If no service is done and as the pressure reaches to 0.4MPa, the by pass valve will open automatically to keep the hydraulic system safe. It is easy to change filter element and to inject the oil to the tank: open the filter cover, the filter element could be changed or the oil can be injected into tank. Two oil ports at filter head which are M18X1.5, the indicator can be installed at any part and they can filter some oil which may return to the tank. The filter has fluid diffuser. The fluid diffuser is at bottom of the filter and can help the medium flow stably to the tank and avoid the air reentering. The filter element is made of glass fiber, so it has high filtration accuracy, low initial pressure loss, high dirt-holding capacity and so on. Filter ratio $\beta_3, 5, 10, 20 \geq 200$, filter efficiency $n \geq 99.5\%$, and fit the ISO standard.

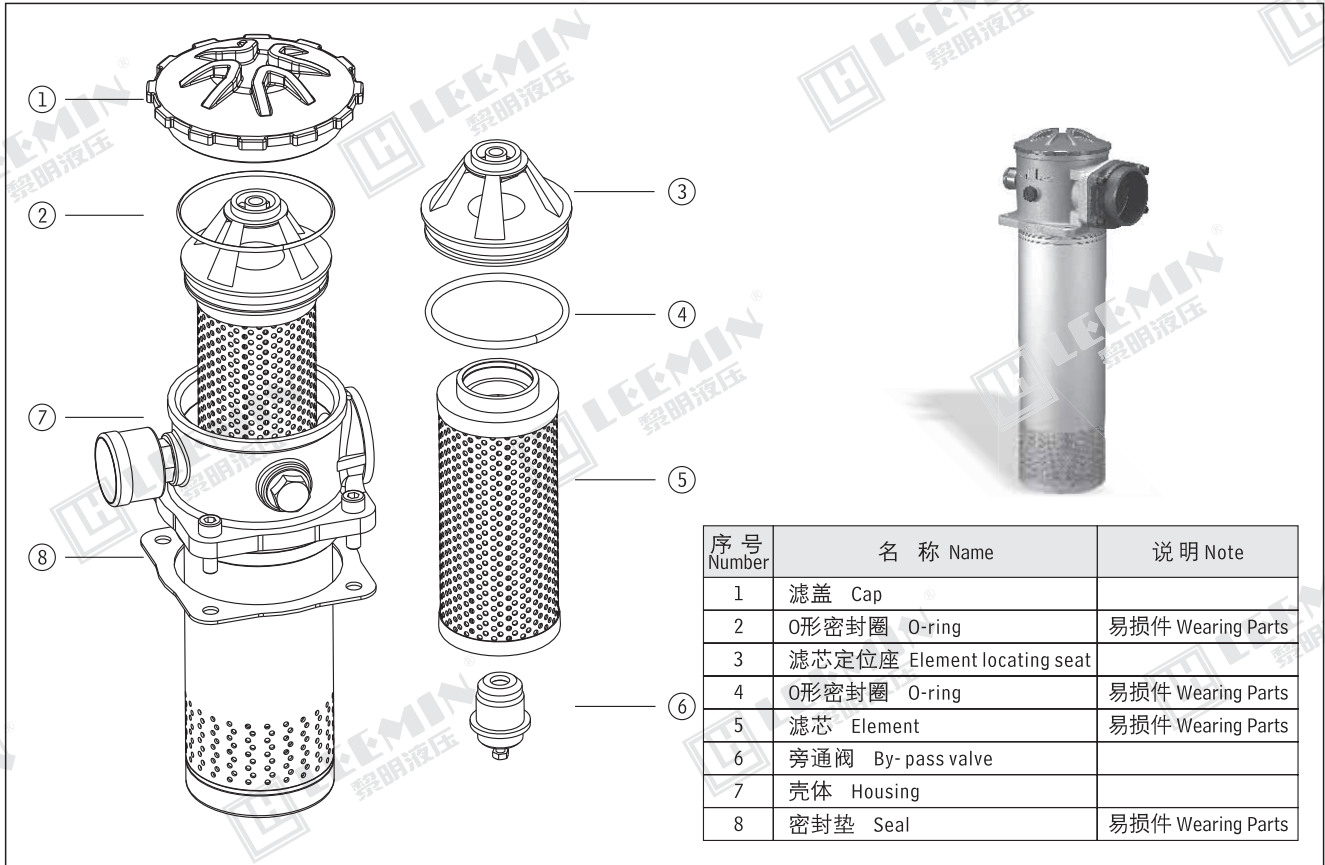

序号 Number	名称 Name	说明 Note
1	滤盖 Cap	
2	O形密封圈 O-ring	易损件 Wearing Parts
3	滤芯定位座 Element locating seat	
4	O形密封圈 O-ring	易损件 Wearing Parts
5	滤芯 Element	易损件 Wearing Parts
6	旁通阀 By-pass valve	
7	壳体 Housing	
8	密封垫 Seal	易损件 Wearing Parts



(三) 安装方法及型号说明 MOUNTING & MODEL CODE

RFA · □ - □ × □ □ - □

微型直回式回油过滤器 Tank mounted mini-type return filter series

BH: 介质为水—乙二醇 Water-glycol

省略: 介质为一般液压油 Omit if use hydraulic oil

公称流量 Flow rate(L/min)

过滤精度 Filtration accuracy(μm)

注: 用户订购过滤器需配【电子模拟发讯器】时, 请与我公司技术部联系。

E: 电子模拟发讯器 Electronic analog indicator

Y: 带CYB-I型发讯器 \leq DC24V With CYB-I indicator

C: 带CY-II型发讯器 \leq 220V With CY-II indicator

省略不带发讯器 Omit if without indicator

L: 出油口为螺纹连接 Threaded connection

F: 出油口为法兰连接 Flanged connection

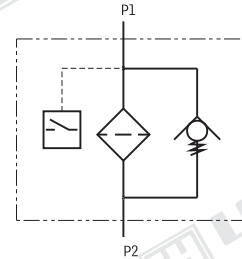
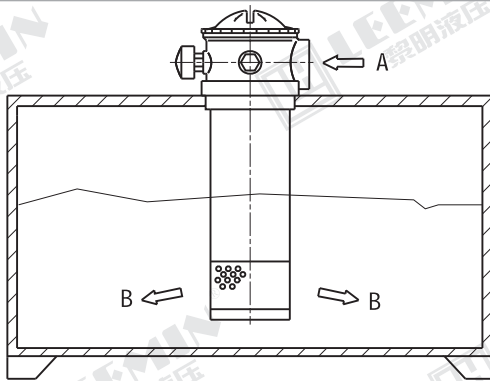

(四) 技术参数 TECHNICAL DATA

型号 Model	公称流量 Flow rate (L/min)	过滤精度 Filtr. (μm)	通径 Dia. (mm)	公称压力 Press (MPa)	压力损失 Initial ΔP (MPa)		发讯装置 Indicator		重量 Weight (Kg)	滤芯型号 Model of element		
					Initial	Max.	(V)	(A)				
RFA - 25 × *L - C	25	3	15	1.6	≤ 0.075	0.35	12	2.5	0.85	FAX - 25 × *		
RFA - 40 × *L - C	40		20								FAX - 40 × *	
RFA - 63 × *L - C	63		25								FAX - 63 × *	
RFA - 100 × *L - C	100		32								FAX - 100 × *	
RFA - 160 × *L - C	160		40								FAX - 160 × *	
RFA - 250 × *F - C	250		10								50	FAX - 250 × *
RFA - 400 × *F - C	400		20								65	FAX - 400 × *
RFA - 630 × *F - C	630		30								90	FAX - 630 × *
RFA - 800 × *F - C	800		90								FAX - 800 × *	
RFA - 1000 × *F - C	1000		90								FAX - 1000 × *	

注: *为过滤精度, 若使用介质为水—乙二醇, 公称流量63L/min, 过滤精度 $10\mu\text{m}$, 带CYB-I型发讯器, 则过滤器型号为RFA · BH-63 × 10Y, 滤芯型号为FAX · BH-63 × 10。

Note: *is filtration accuracy, If the medium is water-glycol, flow rate is 63L/min, filtration accuracy is $10\mu\text{m}$, with CYB-I indicator, the model of this filter is RFA · BH-63 × 10Y, the model of element is FAX · BH-63 × 10.

(五) 滤芯压差流量曲线 ELEMENT PRESSURE DROP (ΔP) AGAINST FLOW CURVES

滤芯 FAX-* × * (由试验测得数据)
Q- ΔP 曲线 油液粘度 Viscosity 30CST

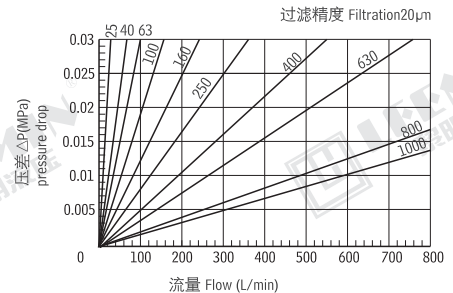
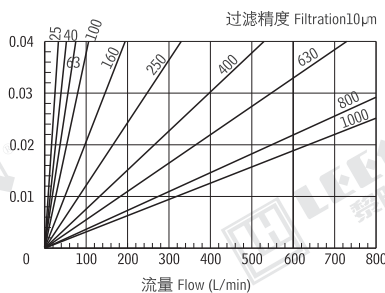
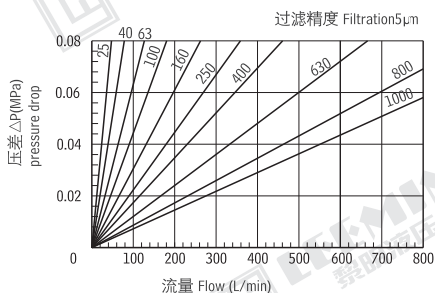



LEEMIN
黎明液压

(六) 连接尺寸 MOUNTING SIZE

1、管式(进油口螺纹连接) Threaded connection

2、法兰式(进油口法兰连接) Flanged Connection

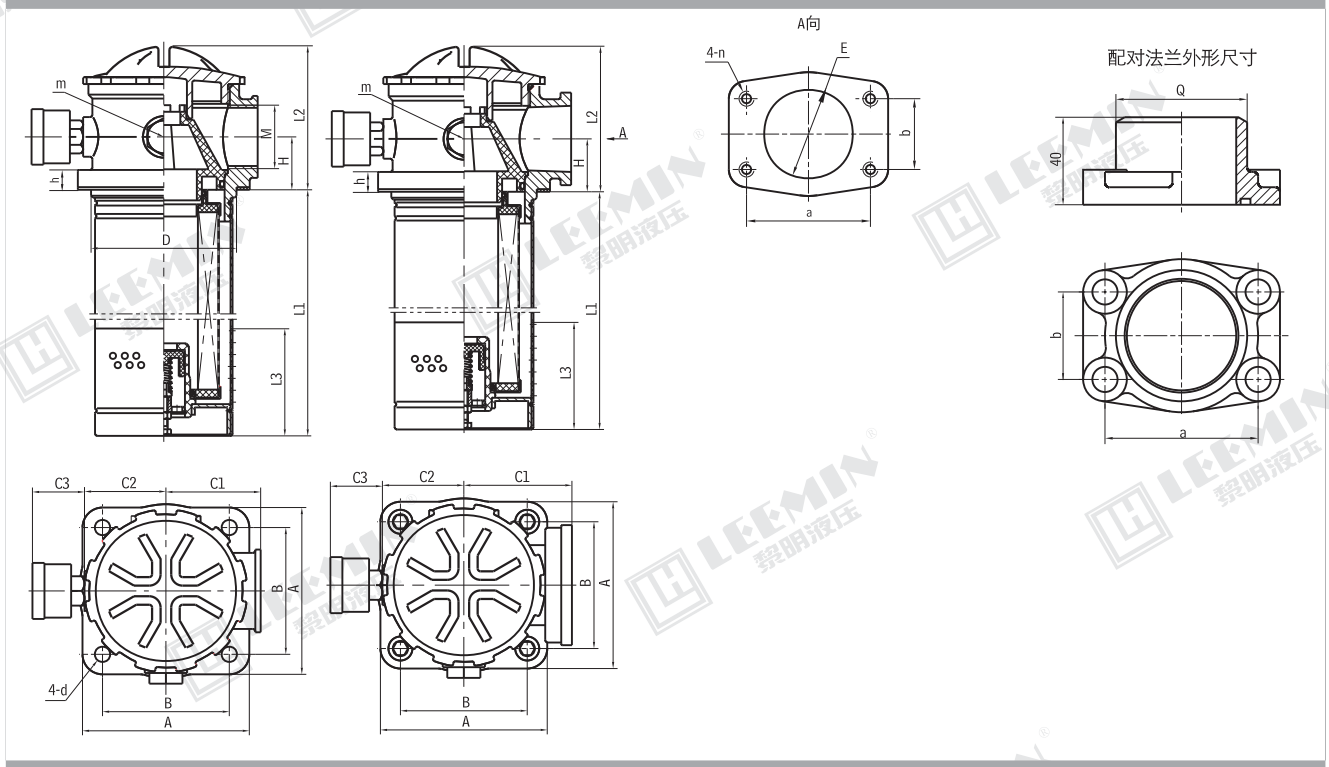

表一：RFA-25~160 管式连接尺寸 Table 1: RFA-25~160 threaded connection

型号 MODEL	尺寸 Size (mm)													
	L1	L2	L3	H	D	M	m	A	B	C1	C2	C3	d	h
RFA-25 × *L - $\frac{C}{Y}$	127	74	45	25	φ 75	M22 × 1.5	M18 × 1.5	90	70	53	45	39	φ 9	10
RFA-40 × *L - $\frac{C}{Y}$	158					M27 × 2								
RFA-63 × *L - $\frac{C}{Y}$	185	93	60	33	φ 95	M33 × 2		110	85	60	53			15
RFA-100 × *L - $\frac{C}{Y}$	245					M42 × 2								
RFA-160 × *L - $\frac{C}{Y}$	322	108	80	41.5	φ 110	M48 × 2		125	95	71	61			

表二：RFA-250~800 法兰式连接尺寸 Table 2: RFA-250~800 flanged connection

型号 MODEL	尺寸 Size (mm)																	
	L1	L2	L3	H	D	E	m	a	b	n	A	B	C1	C2	C3	d	Q	h
RFA-250 × *F - $\frac{C}{Y}$	422	108	80	41.5	φ 110	φ 50	M18 × 1.5	70	40	M10	125	95	81	61	39	φ 13	60	15
RFA-400 × *F - $\frac{C}{Y}$	467	135	100	55	φ 130	φ 65		90	50		140	110	90	68			73	
RFA-630 × *F - $\frac{C}{Y}$	494	175	118	70	φ 160	φ 90		120	70		170	140	110	85			102	18
RFA-800 × *F - $\frac{C}{Y}$	606																	
RFA-1000 × *F - $\frac{C}{Y}$	786																	

注：1)本产品所需的进油口法兰盘，安装连接螺栓及密封圈等配件均和本产品配套提供，用户只需准备好外径 φ Q 的管子焊上即可。

2)2-m为M18 × 1.5螺孔，可在任何一面安装发讯器或作小回油孔之用，并配套丝堵。

Note: The inlet flange, seal, screw of this series will be supplied by our plant. The customer only need weld steel tube φ Q.