



## RF系列直回式回油过滤器

### RF TANK MOUNTED RETURN FILTER SERIES

#### (一) 简介

本过滤器用于液压系统回油精过滤，滤除液压系统中元件磨损产生的金属颗粒以及密封件的橡胶杂质等污染物，使流回油箱的油保持清洁。

1、本过滤器可直接安装在油箱盖板上，也可以用管子安装。

2、设有滤芯污染堵塞发讯器，及旁通阀，提高高压交流的可靠性，当滤芯被污染物堵塞或系统液温过低，流量脉动等因素造成进油压力为0.35MPa时，发讯器便发出讯号指示，应及时更换滤芯或提高温度，若此时不能马上停机处理这些故障时，设在滤芯上的旁通阀会自动开启(开启压力为0.4MPa)

3、滤芯采用玻璃纤维材质，具有过滤精度高，通油能力大，原始压力损失小，纳污量大等优点，其过滤精度以绝对过滤精度标定，过滤比 $\beta_{3, 5, 10, 20} \geq 200$ 过滤效率 $\eta \geq 99.5\%$ 符合ISO标准。

#### INTRODUCTION

This kind of filter is used in the hydraulic system for fine filtration. The filter can filter metal impurity, rubber impurity or other contamination, and keep the tank clean. This filter can be installed on the top of the cover directly or installed with pipe. It has indicator and by-pass valve. When the dirt accumulate in the filter element or the temperature of the system is too low, and the oil inlet pressure reaches 0.35MPa, the indicator will give signals showing that the filter element should be cleaned, changed or rise the temperature. If no service is done and as the pressure reaches to 0.4MPa, the by-pass valve will open. The filter element is made of glass fiber; so it has high filtration accuracy, low initial pressure loss, high dirt-holding capacity and so on. Filter ratio  $\beta_{3, 5, 10, 20} \geq 200$ , filter efficiency  $\eta \geq 99.5\%$ , and fit the ISO standard.

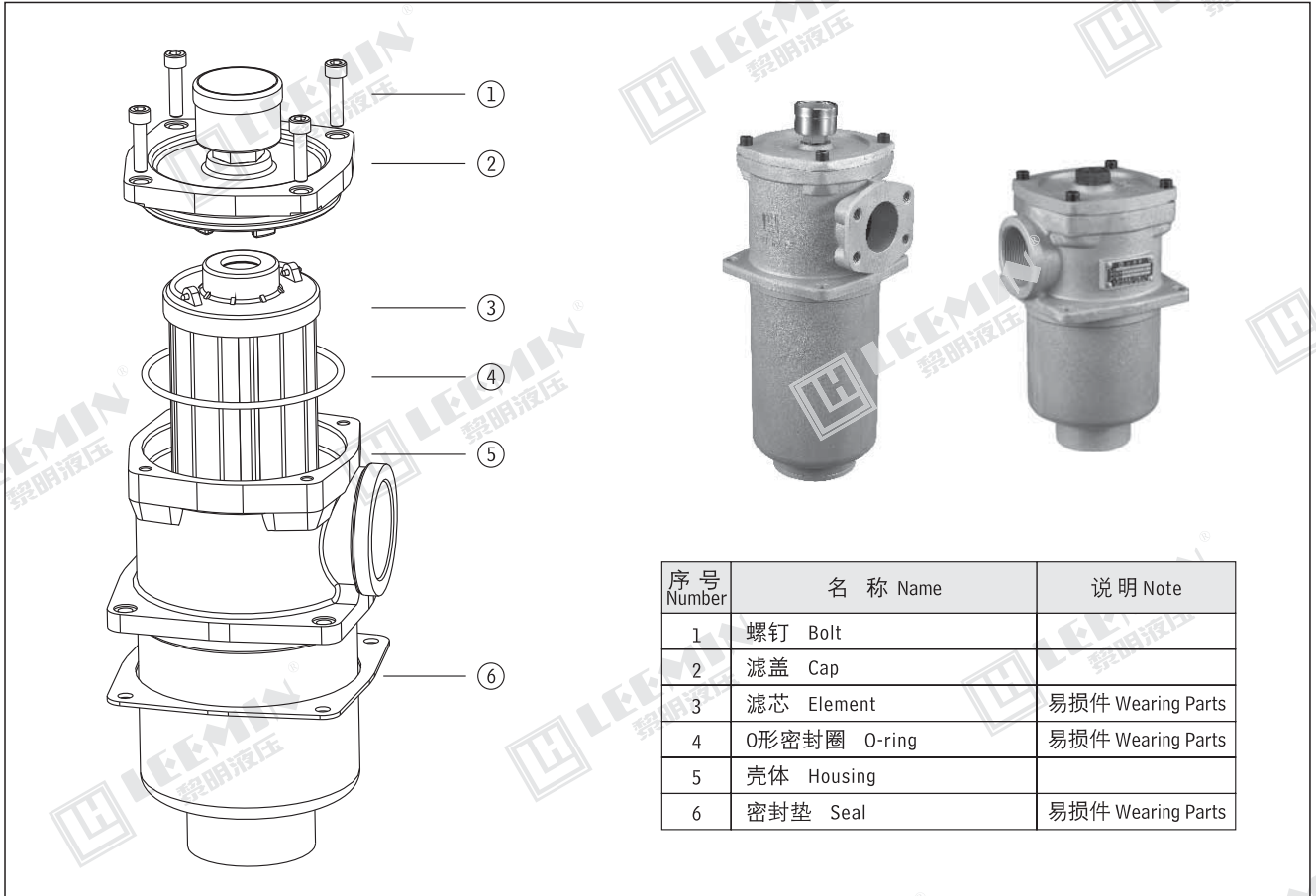

序号 Number	名称 Name	说明 Note
1	螺钉 Bolt	
2	滤盖 Cap	
3	滤芯 Element	易损件 Wearing Parts
4	O形密封圈 O-ring	易损件 Wearing Parts
5	壳体 Housing	
6	密封垫 Seal	易损件 Wearing Parts

#### (二) 型号说明 MODEL CODE

直回式回油过滤器

Tank mounted return filter series

BH: 介质为水—乙二醇 Water-glycol

省略: 介质为一般液压油 Omit if use hydraulic oil

公称流量(L/min) Flow rate

注: 用户订购过滤器需配【电子模拟发讯器】时, 请与我公司技术部联系。

RF · □ - □ × □ □ - □

E: 电子模拟发讯器 Electronic analog indicator  
省略不带发讯器 Omit without indicator

Y: 带CYB-I型发讯器  $\leq DC24V$  With CYB-I indicator

C: 带CY-II型发讯器  $\leq 220V$  With CY-II indicator

L: 为螺纹连接 Threaded connection

F: 为法兰连接 Flanged connection

过滤精度( $\mu m$ ) Filtration accuracy

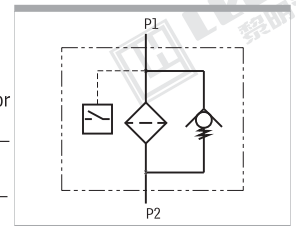



(三) 技术参数 TECHNICAL DATA

型号 Model	公称流量 Flow rate (L/min)	过滤精度 Filtr. ( $\mu$ m)	通径 Dia. (mm)	公称压力 Press (MPa)	压力损失 Initial $\Delta P$ (MPa)		发讯装置 Indicator		重量 Weight (kg)	滤芯型号 Model of element
					Initial	Max.	(V)	(A)		
RF-60 $\times$ *Y <sub>C</sub>	60	3	20	1	$\leq 0.07$	0.35	12	2.5	0.4	LH0060R* BN/HC
RF-110 $\times$ *Y <sub>C</sub>	110		0.9						LH0110R* BN/HC	
RF-160 $\times$ *Y <sub>C</sub>	160		1.1						LH0160R* BN/HC	
RF-240 $\times$ *Y <sub>C</sub>	240		1.8						LH0240R* BN/HC	
RF-330 $\times$ *Y <sub>C</sub>	330		2.3						LH0330R* BN/HC	
RF-500 $\times$ *Y <sub>C</sub>	500		3.2						LH0500R* BN/HC	
RF-660 $\times$ *Y <sub>C</sub>	660		4.1						LH0660R* BN/HC	
RF-850 $\times$ *Y <sub>C</sub>	850		13						LH0850R* BN/HC	
RF-950 $\times$ *Y <sub>C</sub>	950		20						LH0950R* BN/HC	
RF-1300 $\times$ *Y <sub>C</sub>	1300		41.5						LH1300R* BN/HC	

注：\*为过滤精度，若使用介质为水-乙二醇，公称流量160L/min，过滤精度10 $\mu$ m，带CYB-I型发讯器，则过滤器型号为RF·BH-160 $\times$ 10Y，滤芯型号为LH0160R010BN/HC.BH。

Note: \*is filtration accuracy, If the medium is water-glycol, flow rate is 160L/min, filtration accuracy is 10 $\mu$ m, with CYB-I indicator, the model of this filter is RF·BH-160 $\times$ 80Y, the model of element is LH0160R010BN/HC.BH.

(四) 连接尺寸 MOUNTING SIZE

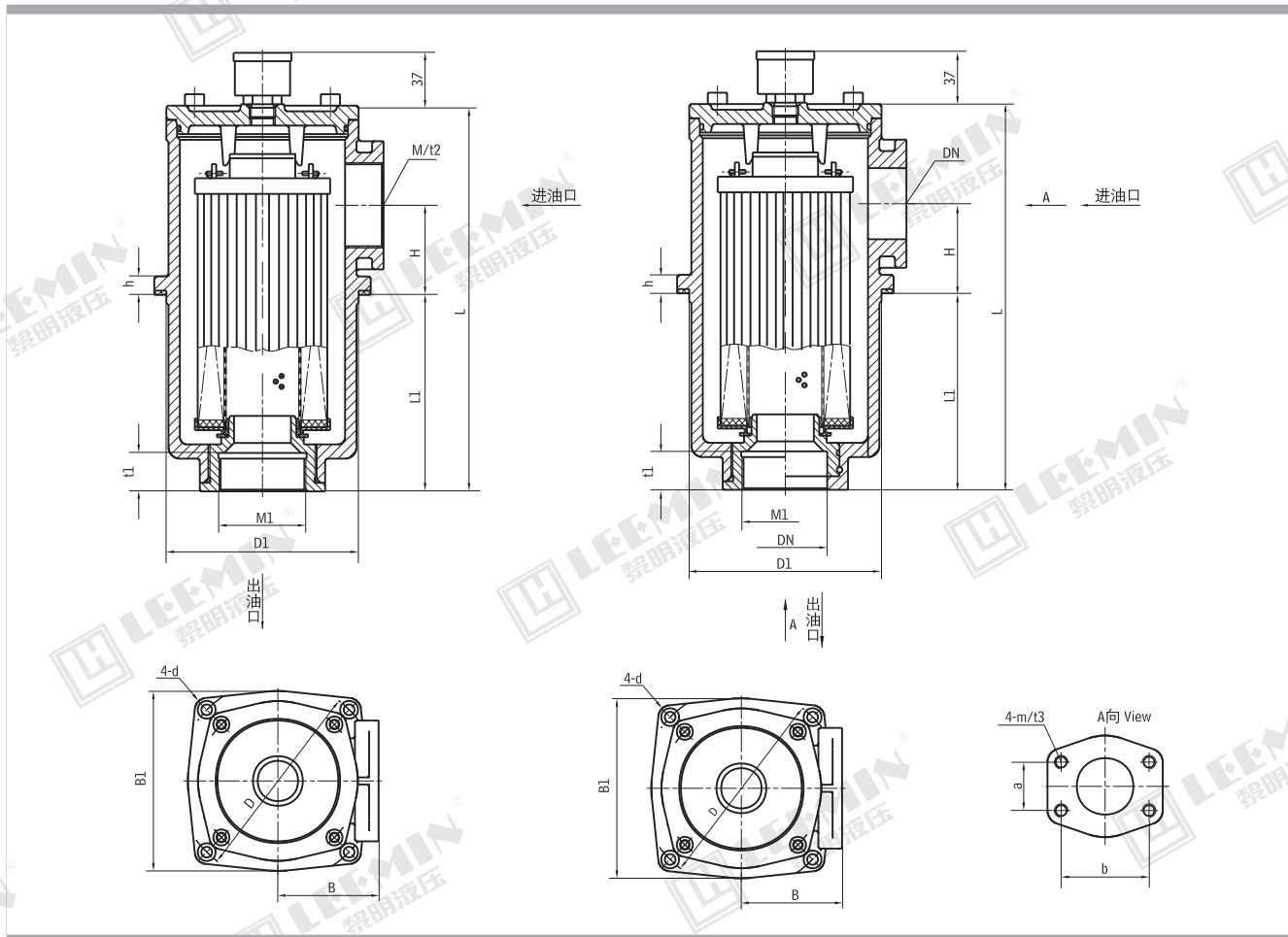



**LEEMIN**  
黎明液压

型号 Model	尺寸 Size (mm)																	
	B1	L	L1	h	D1	H	D	d	M	t2	B	M1	t1	m	t3	a	b	DN
RF-60×*L-Y-C	90	166	92	11	φ 80	34	φ 100	φ 5.5	M27×2	16	48	M27×2	16					
RF-110×*L-Y-C		233	159						M33×2			M33×2						
RF-160×*L-Y-C	120	209	120	11	φ 106	40	φ 135	φ 7	M48×2	20	66	M48×2	20					
RF-240×*L-Y-C		268	179						M48×2			M48×2						
RF-330×*L-Y-C	152	271	138	13	φ 135	63	φ 170	φ 9	M60×2	27	85	M60×2	27					
RF-500×*F-Y-C		351	218						M60×2			M60×2						
RF-660×*F-Y-C	196	411	243	13	φ 175	83	φ 220	φ 13.5			110							
RF-850×*F-Y-C		492	324															
RF-950×*F-Y-C	255	449	251	14	φ 208	93	φ 290	φ 17.5			135							
RF-1300×*F-Y-C		573	332			121												
											145							

注：用户若需英制接口螺纹，请在型号后注上英制螺纹的尺寸。

(五) 滤芯压差流量曲线 ELEMENT PRESSURE DROP(ΔP) AGAINST FLOW CURVES

