



## TRF 系列吸回油过滤器

### TRF SUCTION AND RETURN FILTER SERIES

#### (一) 简介

本过滤器主要适用于闭式回路的液压系统，滤除闭式回路油液中各元件磨损产生的金属颗粒以及密封件的橡胶杂质等污染物，使系统的油液保持清洁，有效地延长液压泵及系统其它元件的使用寿命。

#### (二) 性能与特点

- 1、本过滤器设有积污槽，确保沉积的污染物在更换滤芯时，能随同滤芯一起带出，防止因更换滤芯时污染物重新掉入油箱。
- 2、通过回油系统的全流量过滤，可以去除组装、维修、磨损或从外界进入的灰尘，提高系统油液的清洁度，从而使液压泵得到保护，确保了系统的可靠性。

#### INTRODUCTION

The TRF series filter can be used in the closed loop hydraulic system, and can filter many kinds of contamination like metal granules or rubber impurities in order to keep the oil clean and prolong the service life of pump and other components.

This filter has contamination cup in order to make the contamination removed to gether with the element and prevent the contamination from getting into the tank again when changing filter element.

Please inject the oil to the system until full before the operation of the filter. Start the system and close the oil infusion valve, let the oil flow in the closed system. The filter has oil suction valve. If the system lacks oil because of leaking, the oil will be injected to the system through oil suction valve and oil suction element, so the system is enough supplied with oil. If the return oil in the system is too much, the relief valve at the bottom of the filter will open to let the oil flow back to the tank.

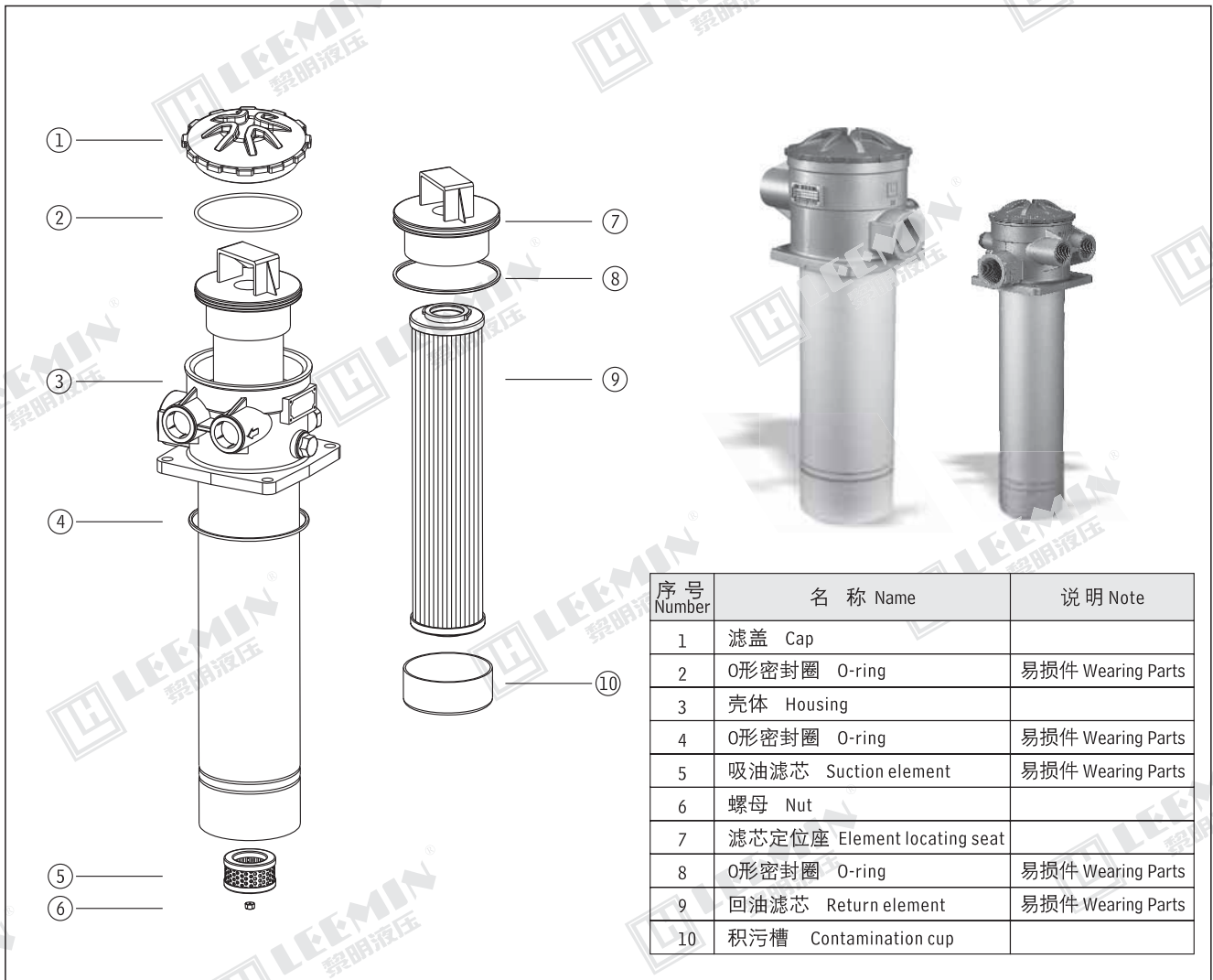



(三)工作原理 PRINCIPILIUM

在过滤器正常运行前，先用补油泵将系统补满油，而后启动系统即可关闭补油泵(系统补油流量小于过滤器补偿流量)，让油液在闭式系统中循环，由于过滤器装有吸油阀，在循环过程中由于

漏油等原因造成系统缺油的情况下，油液经吸油阀和吸油滤芯补充到系统，从而确保了油液的充分供应。当系统油液回油过多时(如油缸的回收)，该过滤器下的安全阀打开，使油液回到油箱。

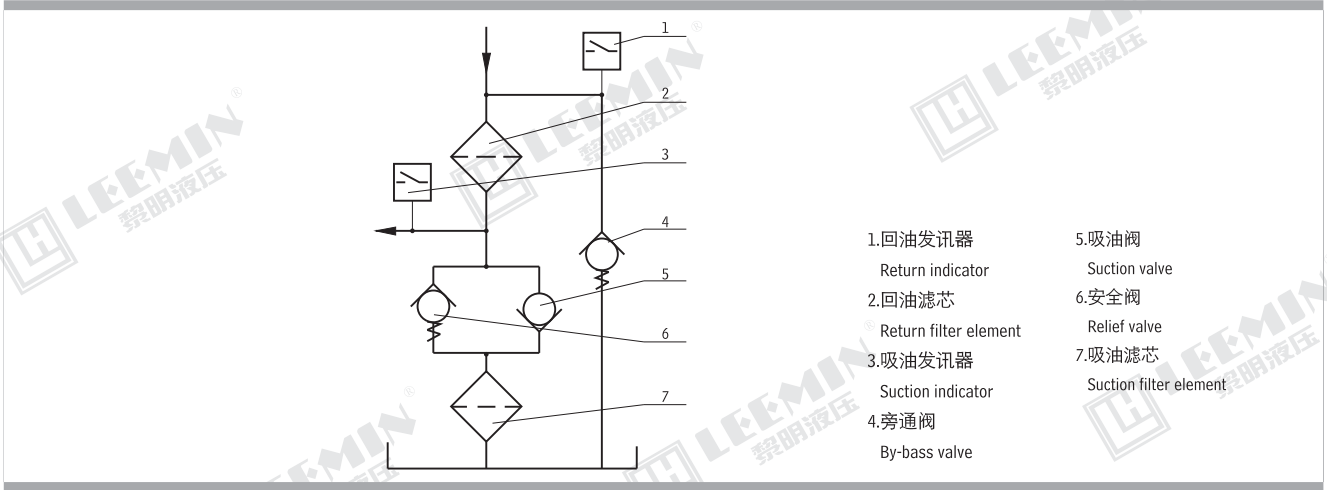

(四)型号说明MODEL CODE

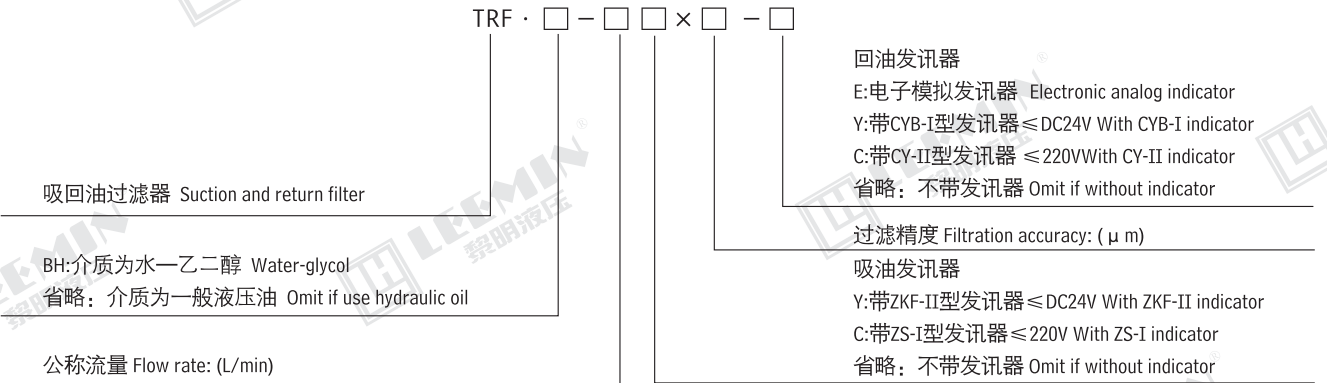

注: 用户订购过滤器需配【电子模拟发讯器】时, 请与我公司技术部联系。

(五)技术参数 TECHNICAL DATA

型号 Model	流量 Flow rate (L/min)	公称压力 Press (MPa)	过滤精度 Filtr. ( μ m)		发讯装置 Indicator		旁通阀开启压力 By-pass valve setting (MPa)	安全阀开启压力 Safety valve setting (MPa)	最大补偿流量 Max. retrieve flow rate (L/min)	回油滤芯型号 Model of element
			吸油	回油	( V )	( A )				
TRF-100 <sup>C</sup> <sub>Y</sub> X* <sup>C</sup> <sub>Y</sub>	100	1	80	10	12	2.5	0.4	0.05	6	TRFX-100X*
TRF-200 <sup>C</sup> <sub>Y</sub> X* <sup>C</sup> <sub>Y</sub>	200				24	2			10	TRFX-200X*
TRF-250 <sup>C</sup> <sub>Y</sub> X* <sup>C</sup> <sub>Y</sub>	250				36	1.5			20	TRFX-250X*
TRF-300 <sup>C</sup> <sub>Y</sub> X* <sup>C</sup> <sub>Y</sub>	300				220	0.25			30	TRFX-300X*
TRF-400 <sup>C</sup> <sub>Y</sub> X* <sup>C</sup> <sub>Y</sub>	400								25	TRFX-400X*
TRF-800 <sup>C</sup> <sub>Y</sub> X* <sup>C</sup> <sub>Y</sub>	800								25	TRFX-800X*

注: \* 为过滤精度, 若使用介质为水—乙二醇, 公称流量100L/min, 回油过滤精度10 μ m, 吸油带ZS-I型发讯器, 回油带CYB-I型发讯器, 则过滤器型号为TRF · BH-100C × 10 - Y, 滤芯型号为TRFX · BH-100 × 10。

Note: \*is filtration accuracy, If the medium is water-glycol, flow rate is 100L/min, return filtration accuracy is 10 μ m, suction with ZS-I indicator, return with CYB-I indicator, the model of this filter is TRF · BH-100C × 10-Y, the model of element is TRFX · BH-100 × 10.



(六) 连接尺寸 MOUNTING SIZE

1. TRF-100

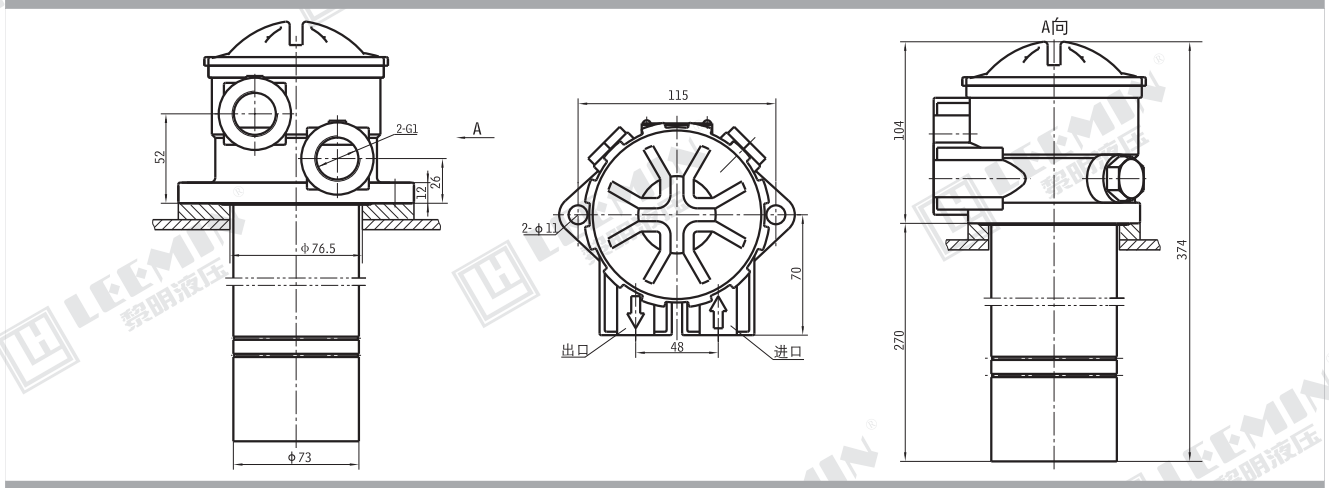

2. TRF-200

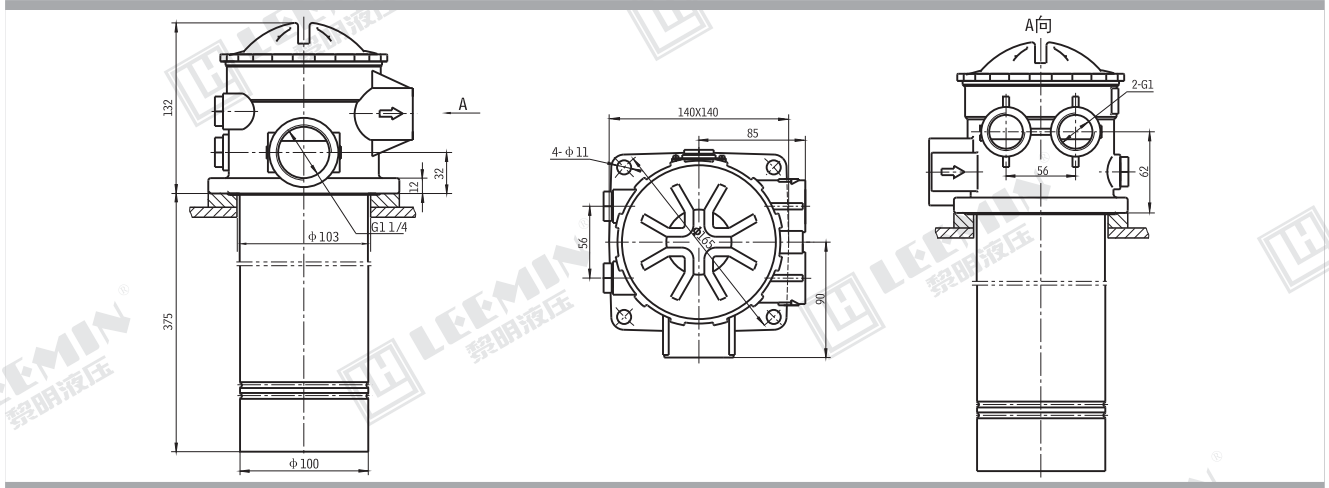

3. TRF-250

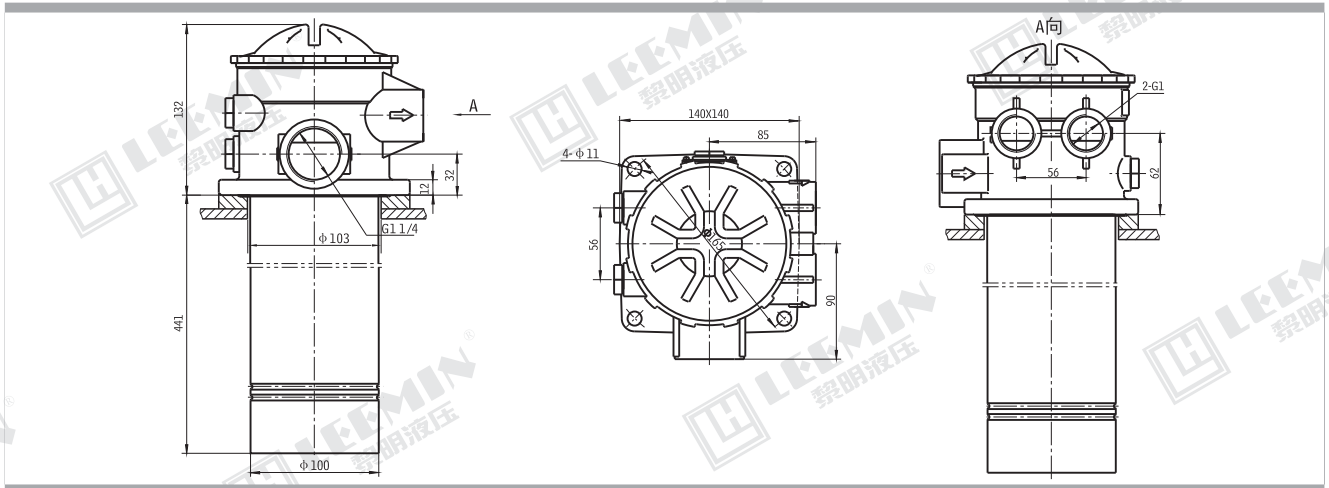



**LEEMIN**  
黎明液压

4. TRF-300

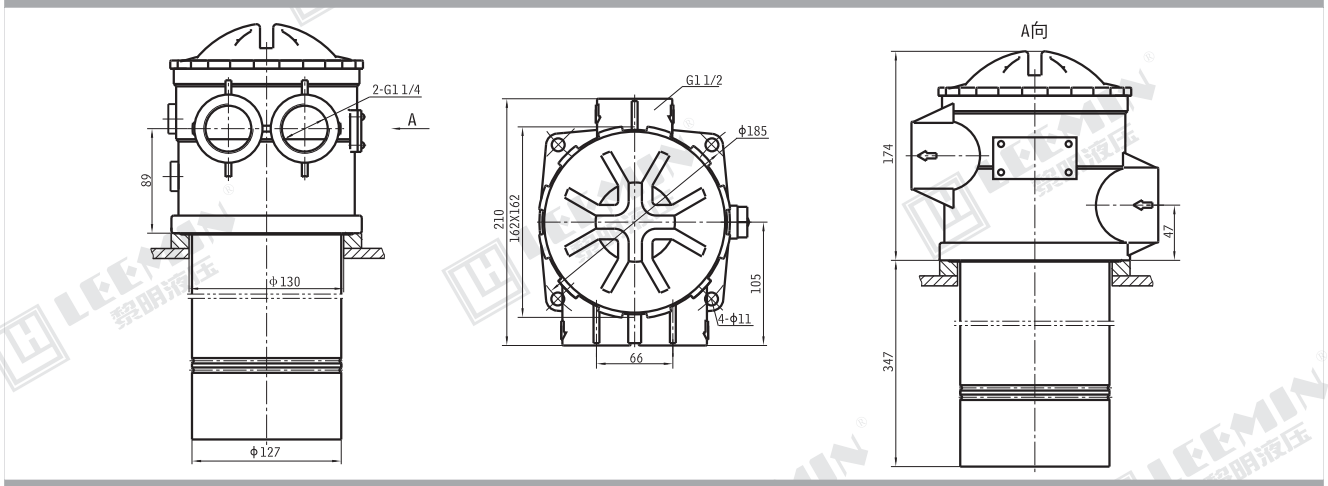

5. TRF-400

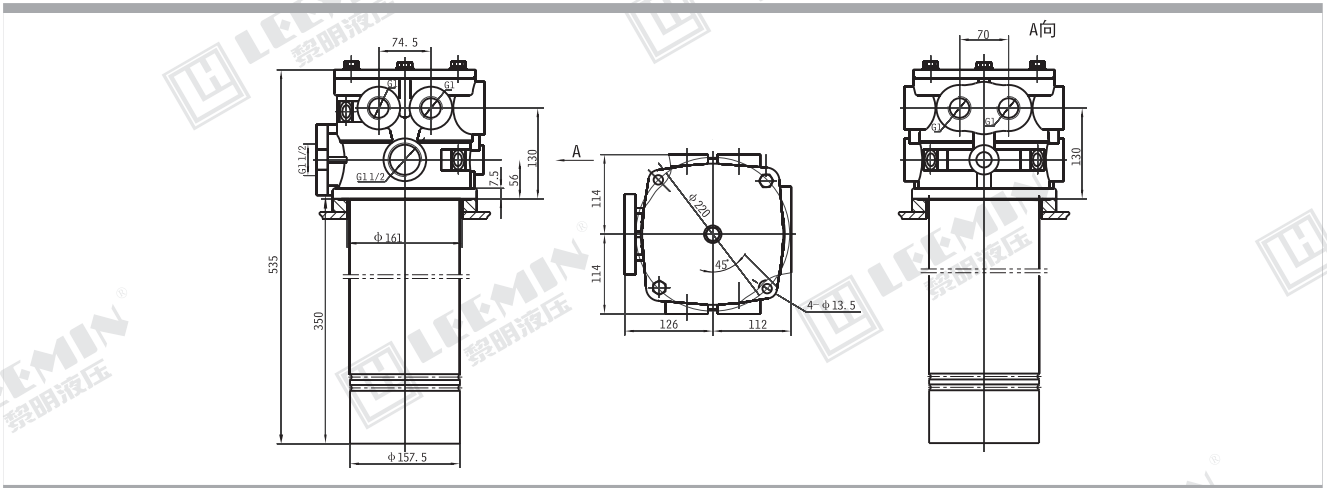

5. TRF-800

