



XYWA—50 ~ 400系列透明小型液位计（新型）

XYWA—50~400 TRANSPARENT LEVEL GAUGE SERIES

(一) 简介 Introduction

我公司生产的XYWA系列液位计可以使用在液压油箱、润滑装置等油箱上，具设计新颖，美观，透明标体材质为PC材料，方便各视角观察液位，且使用压力高于普通液位计。

XYWA series liquid level gauge can be used in the hydraulic oil tank, lubrication equipment such as tank, with novel design. Its transparent body is made of PC material, convenient to see the Angle of each level, and the pressure is higher than ordinary liquid level gauge

(二) 型号说明 MODEL CODE



(三) 安装外形尺寸 MOUNTING SIZE

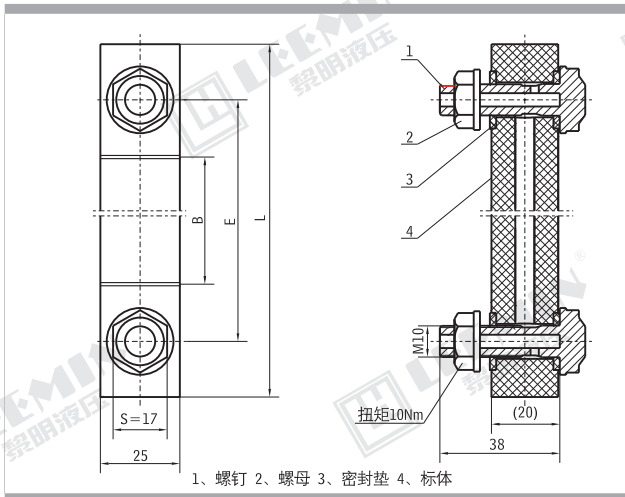

(四) 温度范围及最高使用压力

温度Temp.range:-20℃至+100℃ 并以摄氏和华氏表示

最高使用压力Pressure class:1.6MPa

(五) 安装与使用 Mounting size and Usage

1. 根据选用规格的中心距(E)尺寸,来加工两个安装螺纹孔,如油箱的壁厚>10mm时,可直接加工螺纹孔:M10,若油箱壁薄可以采用焊接螺座方式,需保证安装面的平面度、粗糙度及与螺纹孔的垂直度,以防止安装后漏油问题。

2. 液位计螺钉安装扭矩为:10N·m。

3. 本产品表面切勿与香蕉水等有机清洁剂接触。

According to the specifications of the center distance (E) size, processing two mounting holes. For example, If the tank wall thickness > 10 mm, two mounting screws will be the M10 threaded. If the tank wall is thin. can adopt welding spiral way to mounting. To prevent oil leakage, need to flat the surface of the installation surface.

Level gauge screws install torque is: 10 N · m

Note: Do not contact Lacquer thinner or other Organic cleaner to the surface of the gauge

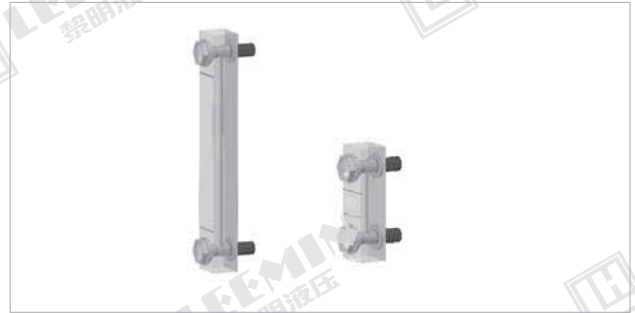

型号 Model	尺寸 Size (mm)		
	L	E	B
XYWA-50	80	50	17
XYWA-76	106	76	43
XYWA-80	110	80	47
XYWA-100	130	100	67
XYWA-125	155	125	92
XYWA-127	157	127	94
XYWA-150	180	150	117
XYWA-160	190	160	127
XYWA-200	230	200	167
XYWA-250	280	250	217
XYWA-254	284	254	221
XYWA-300	330	300	267
XYWA-350	380	350	317
XYWA-400	430	400	367

注:若有特殊规格,请与我公司技术开发部联系

If you have special specification, please contact our technology Dept.