



SYW - 100 ~ 500系列耐高温液位计

SYW - 100 ~ 500 High temperature resistant level gauge

(一) 简介 INTRODUCTION

我司生产的SYW系列耐高温液位计可以使用在液压油箱，润滑装置等油箱上，外壳采用不锈钢材质，标体为玻璃材质，具有耐高温特性，使用温度高于普通液位计，以满足特殊工况场合。

Our SYW series high-temperature liquid level gauge can be used in the hydraulic oil tank, fuel tank, such as lubricating device, The shell is made of stainless steel material, the body is glass material, high temperature resistant characteristics, working temperature is higher than ordinary liquid level gauge, in order to meet the special working condition of occasions.

(二) 型号说明 MODEL CODE

SYW-□
耐高温液位计
High temperature resistant level gauge

螺钉中心距Dimensions: E

(四) 安装外形尺寸 MOUNTING SIZE

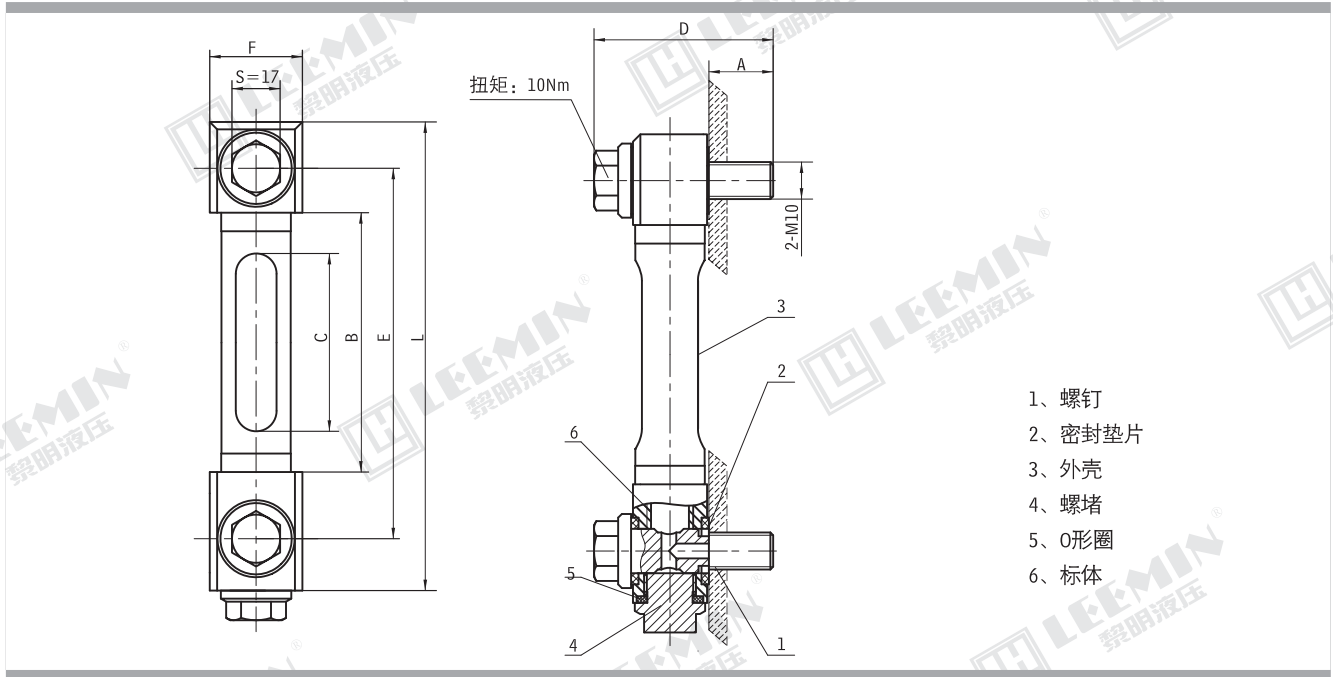

(三) 温度范围及承受压力

- 1、温度Temp.range:-20°C至+150°C
- 2、压力Pressure class:0.15MPa

型号 Model	尺寸 Size (mm)						
	L	E	B	C	A	D	F
SYW-100	127	100	70	48	15	45	25
SYW-127	154	127	97	75			
SYW-150	177	150	120	98			
SYW-160	187	160	130	108			
SYW-200	227	200	170	148			
SYW-250	280	250	217	192		50	30
SYW-254	284	254	221	196			
SYW-300	330	300	267	242			
SYW-350	380	350	317	292			
SYW-400	430	400	367	342			
SYW-450	480	450	417	392			
SYW-500	530	500	467	442			

(五) 安装方法 Installation method

1. 根据选用规格的中心距(E)尺寸，来加工两个安装螺孔，如油箱的壁厚>10mm时，可直接加工螺纹孔:M10,若油箱仅可以采用焊接螺座方式，需保证安装面的平面度、粗糙度及与螺纹孔的垂直度，以防止安装后漏油问题。

2.液位计螺钉安装扭矩为:10N•m。

1.According to the specifications of the center distance (E) size, to machining the two mounting screw holes, such as tank wall thickness > 10 mm, can be directly processed threaded hole: M10, if only can adopt welding spiral way, need to ensure the installation tank surface flatness and roughness and the vertical degree of the threaded hole, in order to prevent the oil leakage problems after installation.

2.The level gauge screw torque for installation: 10 n•m.