



## LKSI液位控制指示器

### LKSI LEVEL CONTROL INDICATOR SERIES

#### (一) 简介

LKSI型液位控制指示器是集液位计(目测),液位控制器(继电器控制)之优点而开发的一种既可目测,又可控制液位的液位控制指示器,适用于敞开或封闭式容器中液位状态的监视与控制。该液位控制指示器是以不锈钢钢管为主体,内装磁性浮子、外装目测磁性翻板指示器以及可任意调节控制点的液位控制继电器而组成。

#### INTRODUCTION

LKSI level control indicator is an advanced visual and electronic control device that can be used for monitoring level of the oil in an open or closed container. It is composed of a stainless steel bowl, magnetic bobbers inside bowl, magnetic plate indicator outside bowl and a relay for controlling fluid level.

#### (二) 工作原理

当容器内的液体通过液位控制指示器主体的下接管时,液体进入不锈钢钢管,使管内的磁性浮子开始上升,管外的磁性翻板在浮子磁力的作用下转动,翻板由绿色转为红色,即磁性翻板绿红颜色的交界处为容器内的液位面。假如容器的液位需要控制三个液位点,只要三个控制继电器固定在相应的液位控制高度,当液位上升或下降到控制点时,控制继电器在浮子磁力的作用下断开或接通,使报警器工作或使油泵电机启动或停止来控制液面位置。如继电器触点接上报警器,还可以作为液位指示报警用。

#### WORK PRINCIPLE

When the liquid in the container passes the lower connect pipe of liquid level control indicator body, the liquid enters into stainless steel pipe to make the magnetic float in the pipe begin to lift, the magnetic wing out of the pipe turns under the function of the magnetic force of the float, the wing turns from the green to the red, that means the juncture of green color and red color of magnetic wing is the liquid level in the container. If the liquid level of the container needs three control points, three control relays can be fixed at the corresponding liquid level control heights, when the liquid level rises or descends to the control point, the control relay is cut off or put through under the function of the magnetic force of the float to make the alarm work or the oil pump motor start or stop to control the liquid level position. If the relay contact touches the alarm, it also can be used for liquid level alarm indicator.

#### (三) 型号说明 MODEL CODE

LKSI □ · □ - □ - □ - □ - □

省略: 不带标尺 Omit: Without ruler

R: 带标尺(仅用于K型) R: Ruler (in K-Type)

省略: 普通开关 Omit: Normal switch used

K: 带磁保持开关 K: Magnetic switch

两连接法兰距离A:

Distance of two flanges A:

液位控制点数: 1、2、3……

Number of control points

省略: 一般液压油 Omit if use hydraulic oil

BH: 介质为水—乙二醇 water-glycol

电压 Voltage: 24V or 220V

液位控制指示器

Level control indicator

- 注: 1、液位控制点间的最小间距90mm, 标准的A为600, 800, 1000, 1200, 1500, 1800mm。  
2、普通开关: 即不带保磁型, 只有当浮球在该点位置上才有动作, 离开该点, 开关触点就恢复原来的状态。  
磁保持开关: 在该点动作后, 浮球离开或下降保持动作后状态。  
3、两连接法兰的距离有特殊要求, 请来电或来函。

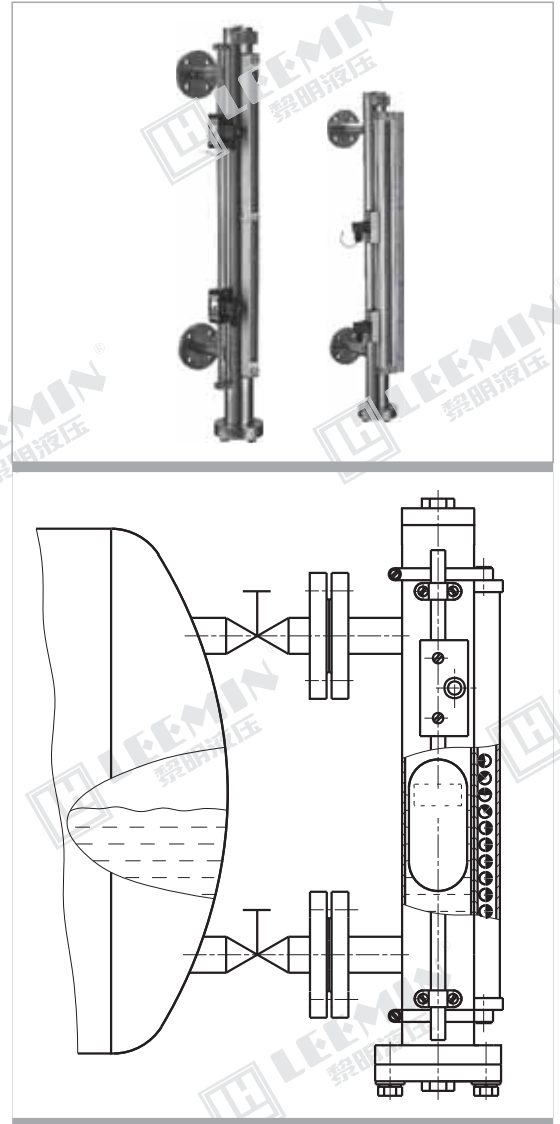

#### (四) 技术参数 TECHNICAL DATA

1、使用环境温度 Temp(°C): -20 ~ +100

2、动作时间 Time of motion(ms): 1.7

3、寿命 Life: (次)10<sup>6</sup>

(一)12V 24V 36VDC

1、接触电阻 Contact resistance(Ω): 0.15

2、触点容量 Contact capacity: DC24(V) × 0.2(A)

(二)110V 220VAC

1、接触电阻 Contact resistance(Ω): 0.2

2、触点容量 Contact capacity: AC220; 110(V) × 0.2(A)



(五)外形尺寸及原理图 MOUNTING SIZE AND GUIDE

普通型

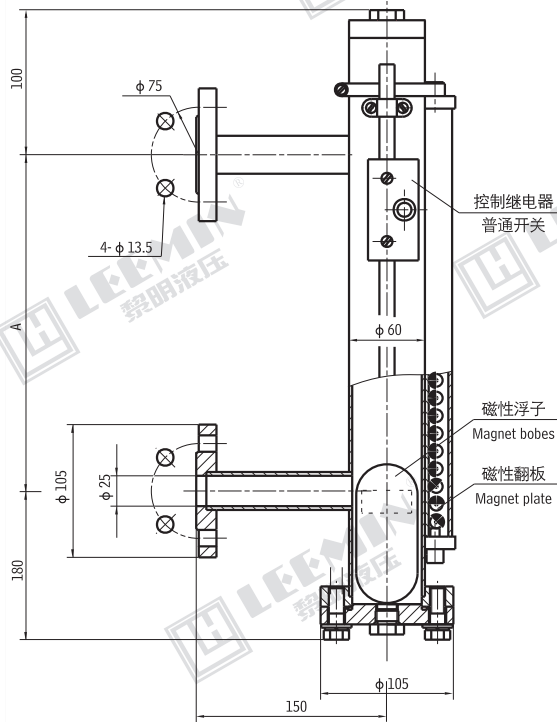

磁保持型

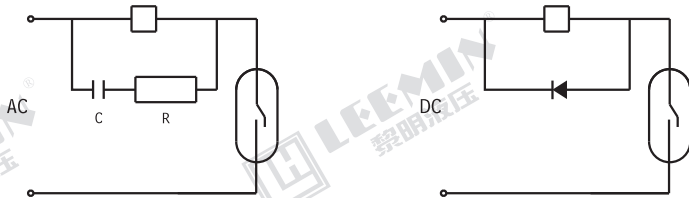
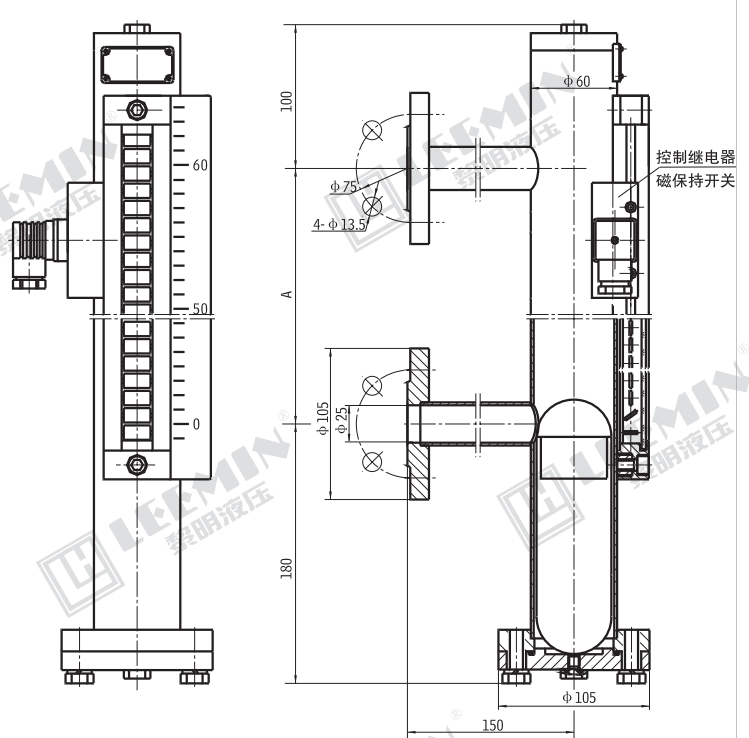

开关触点保护电路

为了防止电感性负载瞬间高感生电压，可能损害触点及明显降低寿命，建议采用触点保护电路。

注：普通开关：220V只有一对常开触点，无常闭触点。

磁保持开关：24V、220V都有常开触点和常闭触点。

(六)使用及维护 USAGE AND MAINTENANCE

- 1、液位控制指示器必须垂直安装在0.3MPa以下的容器上。
- 2、液位控制指示器投入工作前，应先用校正磁钢来校正翻板的绿色面朝外，然后打开上连接管阀门，再慢慢打开下接管阀门，以避免容器内的受压介质急速流入指示器。在不锈钢钢管内，使浮子急速上升，致使磁性翻板指示失灵。
- 3、应定期清除浮子外的吸附物，指示器在工作一段时间后容器内的铁磁性吸附物吸附在浮子的外表面，致使浮子上下浮动不灵活，影响翻板指示器的准确性，清除浮子外的吸附物的步骤：
  - a、关闭上下连接管的阀门；
  - b、扭开排污螺塞，放完主体钢管内的液体；
  - c、打开下法兰盖；
  - d、取出浮子，清除浮子外的吸附物；
  - e、装回浮子时需注意浮子上下朝向，以免指示器及控制继电器出现指示误差和误报警。
- 4、使用时禁止在磁性翻板指示器附近有强力磁场，以免干涉翻板的正常工作。

1. The liquid level control indicator must be installed on the container below 0.3 MPa vertically.
2. Before the liquid level control indicator is put into work, firstly a correcting magnetic steel should be used to correct the green side of the magnetic wing outward, then open the valve of the upper connect pipe, slowly open the valve of the lower connect pipe to avoid the medium pressed in the container flowing into the indicator rapidly. In the stainless steel pipe, the float rises rapidly so that the indication of magnetic wing is out of order.
3. The articles absorbed out of the float should be cleaned regularly. The magnetic articles absorbed in the container are absorbed on the out surface of the float after the indicator works for a period so that the float floats up and down and to affect the accuracy of the wing indicator.
  - a. Close the valves of the upper and lower connect pipes;
  - b. The process to absorb the articles and release the liquid in steel pipe fully;
  - c. Open the lower flange cover;
  - d. Take out the float and clean the articles absorbed out of the float;
  - e. Pay attention to the up and-down direction of the float when reassemble the float to avoid the error indication and wrong alarm of the indicator and control relay.
4. Strong magnetic field is prohibited near the magnetic wing indicator when using in order to prevent from interfering the normal work of the wing.