



SPF系列双筒高压过滤器（新型）

SPF DUPLEX HIGH PRESSURE LINE FILTER SERIES

(一) 简介

该过滤器安装在油泵出口的压力管路上，用以保护控制元件及执行机构。特别是自动控制系统中，高精度的伺服元件及柱塞元件，可有效地防止污染、避免出现故障、延长元件使用寿命。

该过滤器由两只单筒过滤器、旁通阀、换向阀及平衡阀、单向阀、发讯器、排气阀等组成，能实现在系统不停机的情况下，在线压力切换，更换滤芯，特别适合连续工作的液压系统直线压力管路的安装。

当其中处于工作状态的单筒过滤器（手柄或法兰上箭头指向）的滤芯堵塞至压差发讯器压力指示值为0.5 MPa时，发讯器发讯，此时必须更换滤芯。只要提起换向阀手柄，平衡阀将自动开启，再转动换向阀至限位槽，另一只备用过滤器即刻工作，松开手柄，平衡阀将自动关闭。此时只需旋开螺塞放完油，再旋下外壳，就可以更换以堵塞的滤芯。

如因故未能及时更换滤芯压差继续升至旁通阀开启压力

0.6MPa时，旁通阀自动开启，以避免由于压力继续上升，滤芯破裂造成再污染，但用户必须在发讯器发讯时更换滤芯。

Introduction

This series of filter is assembled on the outlet of pressure line to protect the controlling unit, prevent the pollution effectively and extend the working life, especially in the auto-control system.

This duplex filter is made up by two single filters, by-pass valve, balance valve, evacuation valve, indicator and other accessories. It can ensure that the machine needs not to be stopped when changing the element, especially suitable for the assembling of pressure line on the non-stop hydraulic system.

When the pressure showed on the indicator of working side is reaching 0.5 MPa, the element must be changed. Lifting the directional valve, the balance valve would be open automatically, and then turn the directional valve, the other side would start to work immediately.

If the element could not be changed in time, the by-pass valve would be open automatically when the pressure reaches to 0.6 MPa, preventing the element from explosion. The element must be changed when the indicator gives signals.

专利号：ZL 2010 2 0639812.8

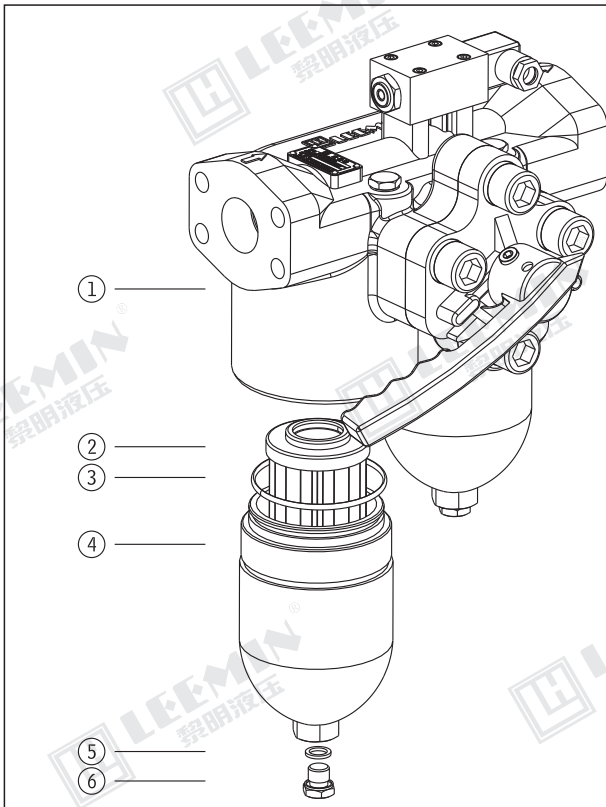

序号 Number	名称 Name	说明 Note
1	滤头组件 Filter head components	
2	滤芯 Element	易损件 Wearing Parts
3	O形密封圈 O-ring	易损件 Wearing Parts
4	壳体 Housing	
5	密封垫 seal	易损件 Wearing Parts
6	螺塞 Screw	

(二)型号说明 MODEL CODE

SPF □ · □ - H □ × □ P
双筒高压过滤器 Duplex high pressure line filter
I: 带旁通阀 With by-pass valve 省略: 不带旁通阀 Omit if use without by-pass valve
BH: 介质为水-乙二醇 Water-glycol 省略: 介质一般液压油 Omit if use hydraulic oil
P: 带CMS型发讯器 With CMS indicator 省略: 不带发讯器 Omit if without indicator
过滤精度 Filtration accuracy (μm)
公称流量 Flow rate (L/min)
公称压力 Pressure class H: 32Mpa

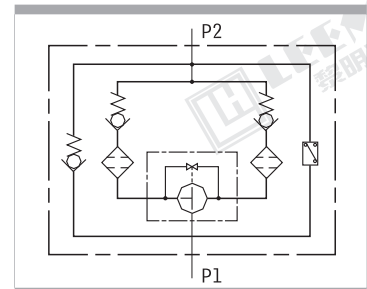



LEEMIN
黎明液压

型号 Model	公称流量 Flow rate (L/min)	过滤精度 Filtr. (μ m)	通径 Dia. (mm)	公称压力 Press. (MPa)	压力损失 Pressure loss(MPa)		发讯装置功率 Indicator power	重量 Weight (Kg)	滤芯型号 Model of element
					Initial	Max.			
SPF-H160X*P	160	3 5	38	32	≤ 0.12	0.5	24V/48W 220V/50W	33 36.5	LH0160D*BN3HC LH0240D*BN3HC
SPF-H240X*P	240	10 20							

(四)安装外形尺寸

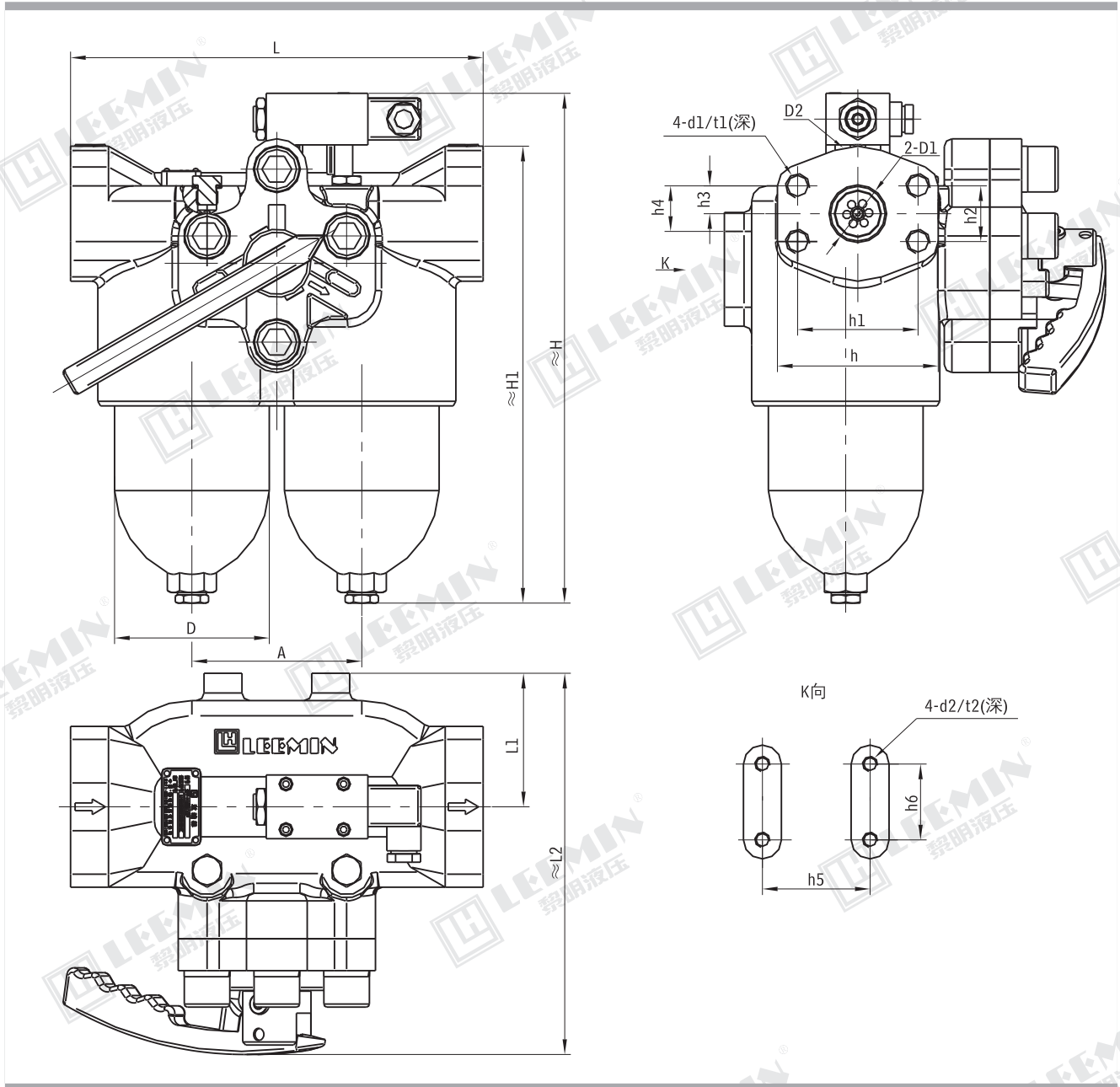

型号 Model	尺寸 Size(mm)																
	L	L1	L2	H	H1	h	h1	h2	h3	h4	h5	h6	D	D1	D2	d1/t1	d2/t2
SPF-H160 × * P	272	88	251	336	301	106	79.4	36.7	18.5	30	71	50	102	38	89	M16/25	M10/15
SPF-H240 × * P				393	358												

注：要求带旁通阀的，过滤器出油口要求管路为通路，不能有关闭现象，以免出现P2口压力大于P1口，造成旁通阀的故障。