



RLF 系列回油管路过滤器 RLF RETURN LINE FILTER SERIES

(一) 简介

RLF 系列过滤器安装在液压系统回油管路处，用来清除油液中诸元件磨损的金属粉末及橡胶质等，使流回油箱中的油液保持清洁。

该过滤器的滤芯采用化纤过滤材质，具有过滤精度高，通油能力大，初始压力损失小，纳污量大等优点，并装有压差发讯器及旁通阀。当滤芯堵塞到进出油口压差为0.35MPa时，便发出开关信号，此时应更换滤芯；如果不能马上停机或无人来更换滤芯，装在滤芯上部的旁通阀会自动开启，以保护系统。

INTRODUCTION

RLF series filter is used in return line, it can remove all the contaminants from the hydraulic system, and allow the clean oil flow back to the tank. The element of this series is made of glass fibre, it has high efficiency and filtration, large dirt capacity and lower initial pressure drop. There is a by-pass valve and a contamination indicator. The indicator will act when the pressure drop across filter element attains 0.35MPa, the element should be changed at this time. If the system can not be stopped or nobody replaces the element, the by-pass valve will open to protect the hydraulic system safety.

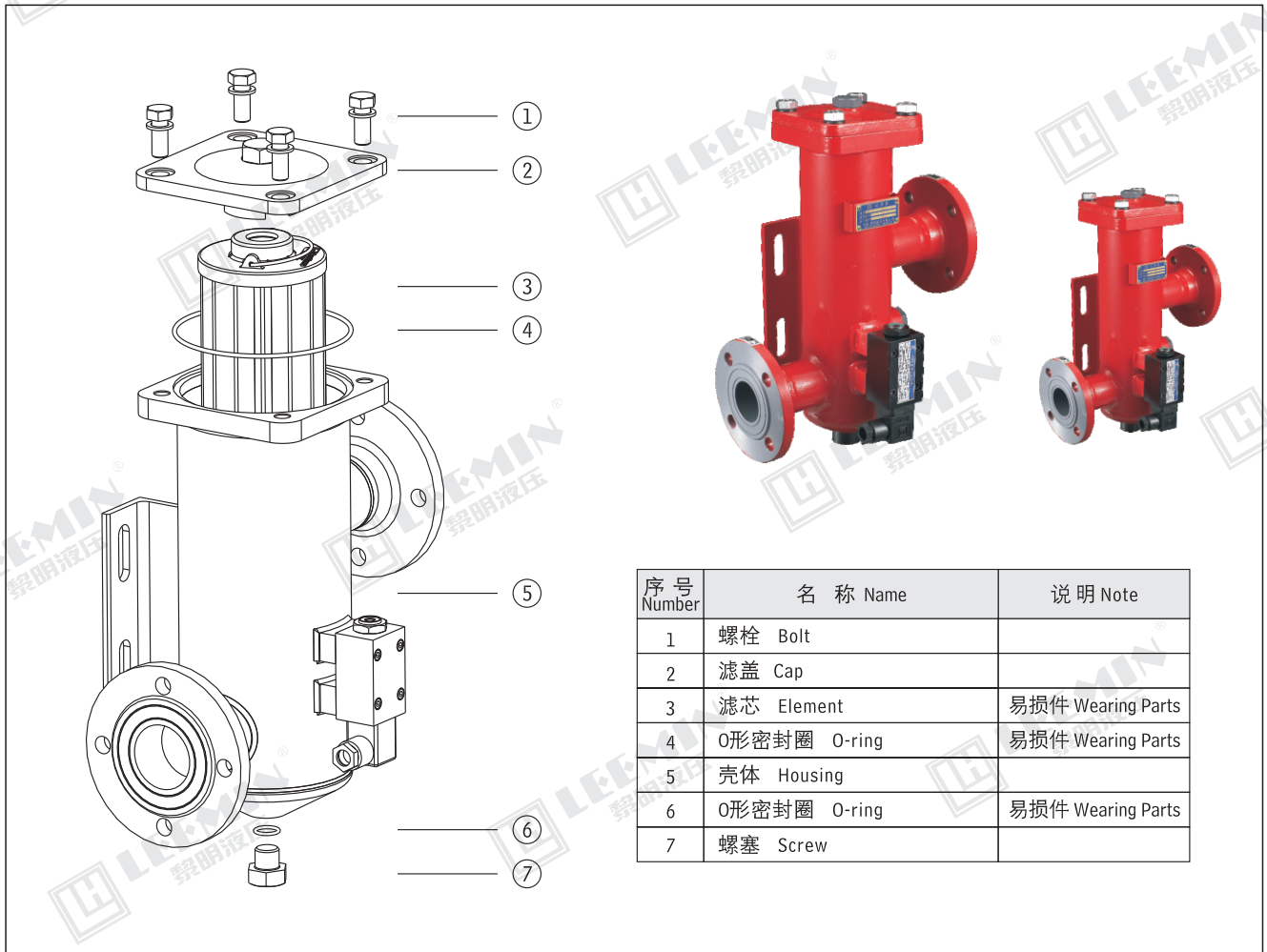

(二) 型号说明 MODEL CODE

RLF · □ - □ × □ □	
回油管路过滤器 Return line filter	P: 带CMS型发讯器 With CMS indicator 省略: 不带发讯器 Omit if without indicator
BH: 介质为水—乙二醇 Water-glycol 省略: 介质为一般液压油 Omit if use hydraulic oil	过滤精度 Filtration accuracy (μ m)
	公称流量 Flow rate (L/min)

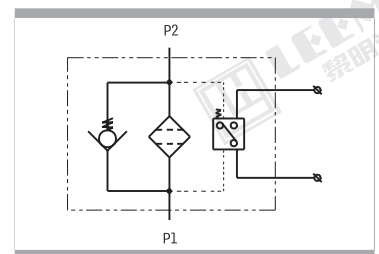



(三) 技术参数 TECHNICAL DATA

型号 Model	通径 Dia. (mm)	公称流量 Flow rate (L/min)	过滤精度 Filtr. (μm)	公称压力 Press. (MPa)	压力损失 Pressure loss(MPa)		旁通阀开启压力 By-pass setting (MPa)	发讯装置功率 Indicator power	重量 Weight (Kg)	滤芯型号 Model of element
					Initial	Max.				
RLF-60 \times *P	25	60	1	1.6	0.2	0.35	0.4	24V/48W 220V/50W	3.7	SFX-60 \times *
RLF-110 \times *P		110								SFX-110 \times *
RLF-160 \times *P	40	160	3							SFX-160 \times *
RLF-240 \times *P		240								SFX-240 \times *
RLF-330 \times *P	50	330	5							SFX-330 \times *
RLF-500 \times *P		500								SFX-500 \times *
RLF-660 \times *P	80	660	10							SFX-660 \times *
RLF-850 \times *P		850								SFX-850 \times *
RLF-950 \times *P	100	950	20							SFX-950 \times *
RLF-1300 \times *P		1300								SFX-1300 \times *

注：*为过滤精度。若使用介质为水—乙二醇，使用压力1.6MPa、公称流量60L/min、过滤精度10 μm 、带发讯器。则过滤器型号为RLF·BH-H60 \times 10P，滤芯型号为SFX·BH-60X10

Note: * is filtration accuracy. If the filter fluid is water-glycol, usage pressure 1.6MPa, flow rate 60L/min, filtration accuracy 10 μm and with CMS indicator. The model of the filter is RLF·BH-H60 \times 10P, the model of element is SFX·BH-60X10

(四) 安装外形尺寸 MOUNTING SIZE

单位Unit:mm

型号 Model	DN	D	D1	d	n	d0	f	b1	h1	A1	L	B	B1	L1	L2	L3	b2	b3	h2	h3	h4	A2	H
RLF-60 \times *P	25	92	68	50	4	11	2	14	60	98	200	149	68	36	14	2	4	11	65	16	20	90	222
RLF-110 \times *P																							289
RLF-160 \times *P	40	120	92	72	4	13.5	3	14	76	125	240	203	110	50	20	15	6	14	75	20	30	120	293
RLF-240 \times *P																							352
RLF-330 \times *P	50	140	110	90	8	17.5	3	20	90	145	280	237	124	55	20	20	6	18	150	25	40	160	368
RLF-500 \times *P																							449
RLF-660 \times *P	80	200	160	133	8	17.5	3	20	115	205	330	279	155	55	20	20	6	22	130	30	40	300	548
RLF-850 \times *P																							630
RLF-950 \times *P	100	220	180	158	8	17.5	3	20	132	225	360	314	170	80	35	20	6	22	130	30	40	300	609
RLF-1300 \times *P																							728

注：若两进油口法兰在同侧则型号为：RLFA-60 \times *P

Note: If flanges of oil inlet and outlet are at the same side, model of this filter is RLFA-60 \times *P

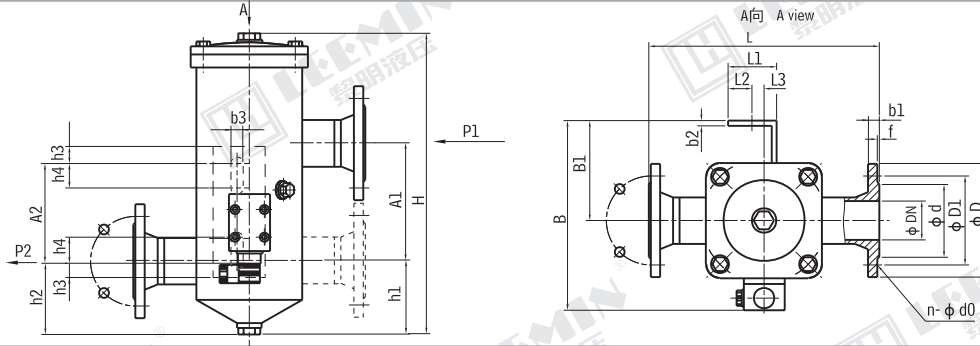

(五) 滤芯压差流量曲线 ELEMENT PRESSURE DROP (ΔP) AGAINST FLOW CURVES

滤芯 SFX-* \times * (由试验测得数据)
Q- ΔP 曲线 油液粘度 Viscosity 30CST

