



HAF系列手动排气预压式空气滤清器 HAF MANUAL EXHAUST BREATHER FILTER SERIES

(一) 简介

HAF系列预压式空气滤清器是我司根据客户要求结合实际开发的产品,该系列产品主要配套使用在各种挖掘机及需要具有压力的液压系统油箱配套使用。

本产品主要由空气滤清器、进气单向阀、排气单向阀及手动排气装置四部分组成,当液压系统工作时油箱内的液面下降时,外界空气经过空气滤清器,进气单向阀进入油箱,能保持油箱内的压力的平衡,提高油泵的自吸能力,维持油箱内液体的平稳,当工作循环后液体流回油箱使液面上升,由于空气压缩增加了油箱内的压力,当油箱内的压力大于排气阀的预定压力时,油箱内的空气会克服排气阀的压力,经排气阀。空气滤清器排到大气中,直到箱内的压力等于预定压力值,排气阀才会自动关闭。

该产品上部设有手动排气装置,当系统检修需要油箱泄压时,旋下排气阀上面的防尘帽,按下手动排气装置,即可实现油箱内排气泄压,并且该空气滤清器底部带有防溅油装置,能够有效防止在工作中因为油箱的晃动而导致油液溅出,该产品结构合理,外观设计新颖,安装方便,深受广大用户欢迎。

(二) 型号说明: MODEL CODE

HAF□-□	排气阀开启压力(MPa)
手动排气预压式空气滤清器 Manual exhaust breather filter series	型号Model: 1、2、3……

(三) 技术参数: TECHNICAL DATA

型号 Model	HAF1	HAF2	HAF3
空气过滤精度Air filtration(μm)	10		
排气阀开启压力Exhaust valve setting(MPa)	0.02	0.035	
温度适应范围Temp. range(°C)	-20 ~ +100		
空气流量 Air flow rate(m ³ /min)	0.45		

INTRODUCTION

HAF manual exhaust breather filter is combined with the actual development according to customer's requirements, mainly used in all kinds of excavator and hydraulic system tank.

This product is mainly composed of air filter, air inlet check valve, exhaust check valve and manual exhaust system total four parts, when the hydraulic system oil level drops, the air inbreathed in the air filter into the tank, which maintain the balance of the pressure inside the tank, improve the oil pump self-priming capacity, and the stable of the oil in the tank, When the oil level rise, due to compressed air, the pressure rise in the tank, when the pressure inside the tank is over the exhaust valve setting pressure, the air in the tank will exhaust from the exhaust valve, until the pressure reached to the setting pressure, the exhaust valve will automatically close.

The product is equipped with manual exhaust system, when the system maintenance require drop the tank pressure, unscrew the dust cap of the exhaust valve, press the manual exhaust bottom, which can release the pressure in the tank, the breather filter is also with splash proof device, prevent the sloshing in the tank caused by the oil splash. With reasonable design and easy installation, the customers are very popular with this product.

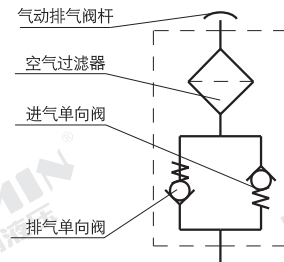

符号及工作原理图 Circuit symbol

(三) 安装外形尺寸: MOUNTING SIZE

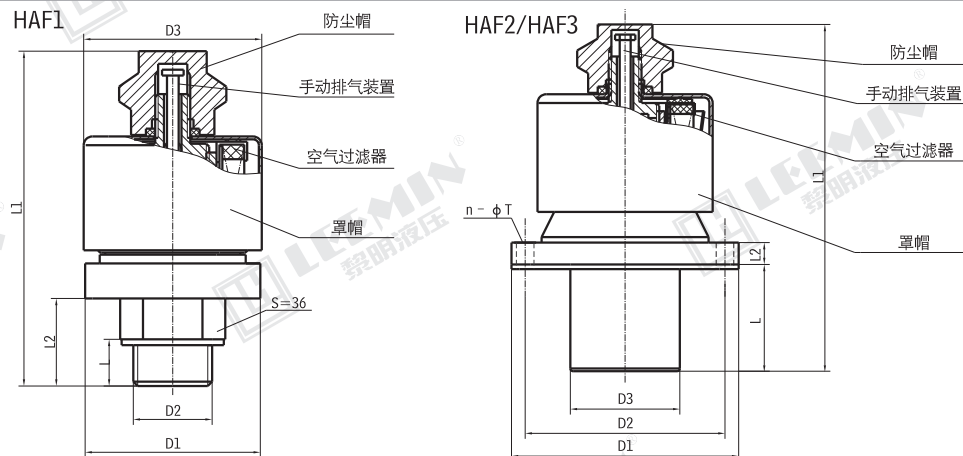

单位unit: mm

型号 Model	D1	D2	D3	L1	L2	L	T	n
HAF1	60	G3/4	60	113	30	16	/	/
HAF2	83	73	40	128	8	39	5	6
HAF3	90	75	40	128	12	39	7	4