



SL系列旋流式油冷却器

SL SPIRAL TYPE OIL COOLER SERIES

(一) 简介

本油冷却器用以保护液压系统工作时，液压元件产生各种能量的消耗，几乎全部转化为热量，从而使工作油液的温度及液压元件的温度升高，而引起造成液压元件损坏的一种冷却装置。每种液压元件都有耐温极限，温度过高(> 80°C)将严重影响液压系统的正常工作。

本油冷却器是一种新型，高效冷却器。它主要用于液压和润滑系统，将工作油液冷却到规定的温度。因此广泛适用于化工、电力、矿山、轻工等行业的各种液压设备的冷却，尤其适用于机械设备空间狭小紧凑的液压系统场所。如：注塑机，压机等机器上，是一种较为理想的冷却装置。

(二) 性能与特点

- 1、本油冷却器采用螺旋导流板引导油流成螺旋形均匀连续流动，克服了传统折流板产生的油流换热死角，提高了换热效率。
- 2、本油冷却器采用螺旋导流板和翅片传热管，具有换热效率高，压力损失少，重量轻和体积小等优点，是一种较经济型的产品。
- 3、本油冷却器采用先进的机械胀管制造工艺。进出油路上设置了螺纹连接，方便了与液压系统设备的连接。
- 4、油侧使用压力不大于1.6MPa。

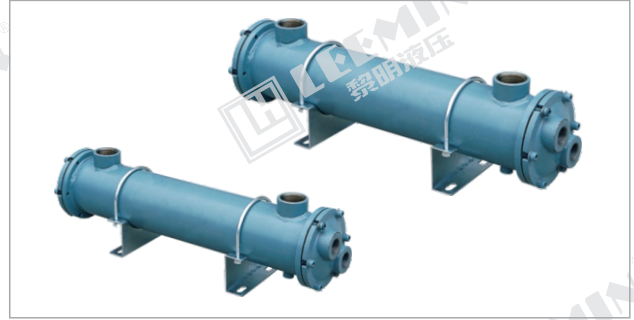

INTRODUCTION

During operation of the hydraulic system, the hydraulic elements' temperature will rise. when the temperature is above 80°C, that will make the hydraulic system out of order.

So at this time we need a cooler. This product is a new type and high efficiency cooler, mainly used in low-viscosity hydraulic and lubricates system to cool the work oil to the specified temperature. So it is an ideal cooling facility that can be widely used in cooling the hydraulic equipment in the trade such as chemical industry, electric power, and metallurgical industry, mine and light industry and so on, specially can be used in narrow and compact hydraulic system like injection molding machine.

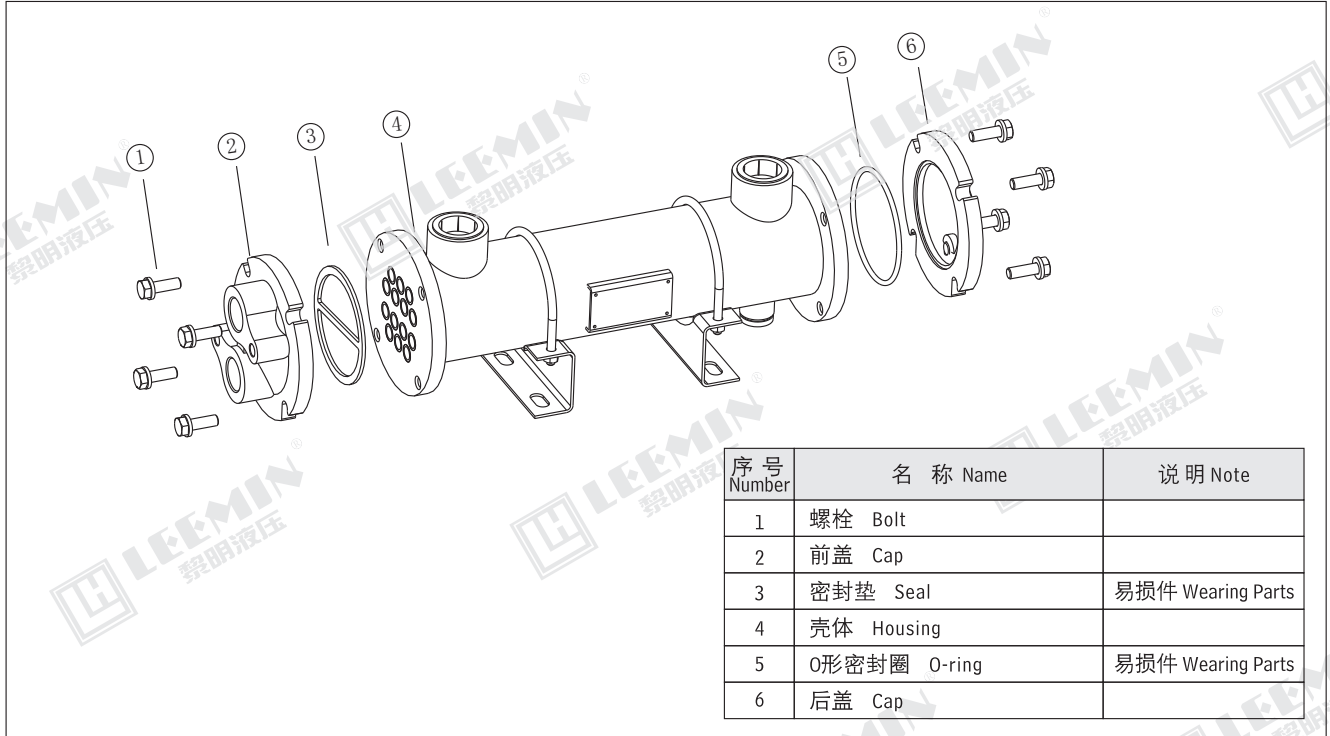

(三) 型号说明 MODEL CODE

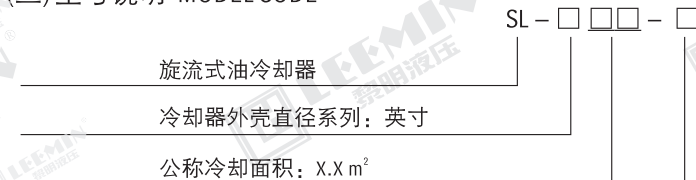

特殊品:B:壳体不锈钢
H:适用于冷却水为海水
进出油(水)口尺寸不同请直接标明
其它要求FB-□
标准品可省略



LEEMIN
黎明液压

(四)外形尺寸 MOUNTING SIZE

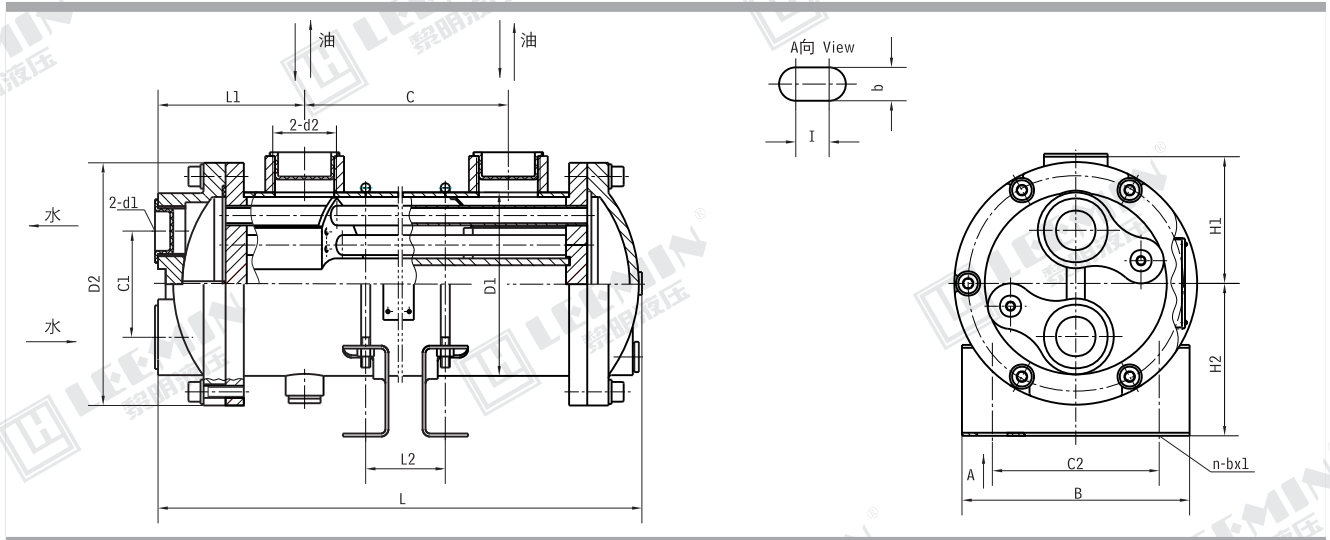

型号 Model	L	C1	C	L2	L1	H2	B	C2	n-b × I	H1	D2	D1	d2	d1	重量 Weight (Kg)
SL-303	305		152	107											4.5
SL-304	377		224	179											5
SL-305	450		296	251											5.5
SL-307	593	45	440	395	80	85	115	75	4-11 × 20	64	120	87.9	G3/4	G3/4	6
SL-309	737		584	539											7
SL-311	880		728	683											8
SL-408	467		284	240											14
SL-411	610		428	384											17
SL-415	755	75	572	528	94	100	150	110	4-10 × 20	85	160	121	G1 1/4	G3/4	19
SL-418	900		716	672											22
SL-421	1042		860	816											25
SL-512	528		298	206											20
SL-518	635		406	342											22
SL-526	852	70	622	558	121	140	180	135	4-18 × 25	95	180	139.8	G1 1/2	G1	27
SL-534	1070		838	774											32
SL-542	1285		1054	990											38

注：本公司可以根据用户的要求制造各种大型的、特殊的冷却器。

(五)性能曲线 TECHNICAL CURVE

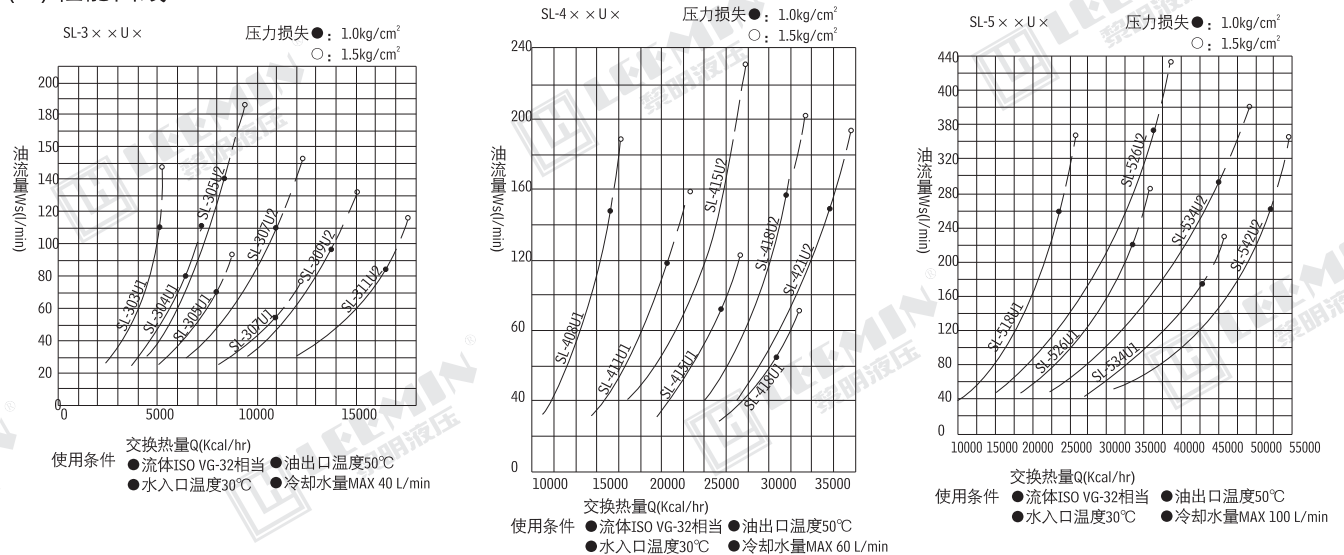



(六)选用冷却器的方法

1、计算需交换的热量：Q(Kca L/h)

(1)根据油液的温度要求和流量计算：

$$Q = CW(T_1 - T_2)$$

式中 C—油的比热(Kca L/kg°C) W—油的流量(kg/h)
T₁—进口油温(°C) T₂—出口油温(°C)

其中：W=qP

式中 q—油的流量(L/min) P—油的密度(kg/L)

(2)根据液压系统的发热量计算：

$$Q = Pr - Pc - Phc$$

式中 Pr—液压系统的输入功率 Pc—输出有效功率
Phc—油箱、管道散热功率

2、选择冷却器型号

根据计算出的换热量Q和油流量Ws查产品性能曲线，两者交点，即为所选的型号。

3、补充说明

冷却器的实际使用条件可能与其性能测试条件有区别。油粘度小，水流量大，油温与水温温差大时，可选取用比所选型号偏小的型号，反之，选取偏大的型号。



使用须知和清洗方法

APPLIANCE NOTES & CLEANNESS

(一) 使用须知

1、操作规程:

- (1)启动前检查所有附件与仪表并查看各连接处是否紧密。
- (2)拧下处于冷却器出油口外的螺塞(用户配), 然后缓缓开启进油阀(此时排油)阀处于关闭状态。当油溢出时, 关闭进油阀, 拧上螺塞。
- (3)拧开冷却器管路中排气阀, 然后缓缓开启进油阀(此时排水阀处于关闭状态)。当水充满后, 关闭进油阀和排气阀, 此时水和油均成静止状态, 经热交换后, 温差逐渐变小。
- (4)当水温升高5-10°C后, 打开冷却水和油的排出阀, 再逐渐打开冷却水和油的进入阀, 使冷却水和油均处于流动状态。然后调整冷却水的流量, 使之出油温度保持在正常工作状态。
- (5)冷却器因故障或正常停止工作时, 其操作步骤先关闭油和冷却水的进入阀, 然后关闭油和冷却水的排出阀, 再拧下排水、排油接口上的螺塞, 排尽积于冷却器内的冷却水与油。

2、注意事项:

- (1)在启动冷却器工作时, 切忌快速打开进水阀门, 因冷却水大量流过冷却器时, 会使换热管表面形成一层导热性很差的“过冷层”, 即使以后水量很大, 也起不到最佳的冷却作用。
- (2)如果水侧发生电化作用的腐蚀, 可以在进出水盖的指定位置(预留孔内)自行安装防电化的锌棒。
- (3)冷却水通常采用净化的淡水, 使用江河水时在进水口须配置滤水器。
- (4)为提高热交换性能, 防止水垢形成, 冷却水温度尽可能要低些, 水流量要大些。
- (5)冷却器的油侧压力应大于水侧压力。
- (6)在寒冷季节, 且冷却器不工作的情况下, 必须将水放尽, 以免冻裂。

(二) 清洗方法

冷却器长期工作时, 管壁表面逐渐积垢, 热交换性能下降, 以至不能保证冷却要求, 此时必须停用清洗, 清洗周期视水质情况而定, 一般每5-10个月应进行一次内部的检查和清洗。其方法如下:

1、水侧清洗:

用软管引洁净水高速冲洗前盖, 后盖内壁和换热管内表面, 同时用清洗通条进行洗刷, 洗毕后用压缩空气吹干。

2、油侧清洗:

(1)用三氯乙烯溶液进行冲洗, 使清洗液在冷却器内循环流动, 溶液压力不大于0.6MPa, 溶液的流向最好与冷却器油流方向相反, 清洗时间视污垢情况而定, 然后再将清水灌入冷却器内清洗, 直至流出的水清洁为止。

(2)用浸泡法将溶液灌入冷却器。历时15-20分钟后查看溶液颜色, 若混蚀不堪, 则更换新溶液, 重新浸泡, 直至清洁为止, 然后用清水冲净。(若采用四氯化碳清洗时, 应在良好的通风环境下进行, 以免中毒)

(3)清洗后进行液压试验, 也可用0.7MPa气压试验替代, 然后装到系统上使用。

APPLIANCE NOTES

1.Operation Standards

- (1).Before operation, check all the parts and instruments, and check each joint is sealed or not.
- (2).Screw down the plug screw at the oil outlet of the cooler, then slowly start the oil inlet valve (at this time, the oil drain valve is in the closed state). When the oil flow out, closed the oil inlet valve, and tighten the plug screw.
- (3).Rive the exhaust valve of the cooler pipeline, then slowly start the water inlet valve(at this time, the water exhaust valve is in closed state). When the water is enough, close the water inlet valve and the exhaust to valve, and this time, both the water and oil is in the state of rest, and the range of temperature is lessened after heat exchange.
- (4).When the water temperature raised to 5-10°C, open the oil and cooling water exhaust valve, and then slowly open the cooling water and oil inlet valve to make the oil and water in the state of flowing. Then regulate the flow of the cooling water to keep the oil temperature in the nominal working state.
- (5).The cooler is stopped runing whether because of the fault or normal stop. Its operation step is that firstly close the oil and cooling water inlet valve, next close the oil and cooling water exhaust valve, and then screw down the plug screw at the nozzle of the oil outlet and water outlet to exhaust the ooling water and oil which store up in the cooler.

2.notes:

- (1).When start the cooler to work, do not open the water inlet valve quickly, for if large quantity cooling water flow through which with the cooler result to a "surfusion"?formed on the surface of the heat-exchange pipe, and then the cooling effective is not optimum even with large water yield.
- (2).If electrochemical corrosion happened, install an antielectrochemical Zinc club in the appointed place on the water inlet and outlet cover.
- (3).Normally uses the purified fresh water as cooling water. If use the water of river, must install a water filter at the water inlet.
- (4).To raise the heat-exchange unction and avoid of forming the water shouldscale, the cooling water temperature should be lower and the water yield be larger.
- (5).The pressure in oil side of cooler should be larger than the water side.
- (6). In cold season and the cooler does not work, do exhaust out the water to avoid of frost crack.

CLEANNESS

After a long period operation, the surface of pipe-wall of the cooler begri me continually with heat-exchange function falling which results in insuring the cooling quality. At this time the cooler must be stoped to clean. The clean circle is defined according to the water quality, normally carry out internal checking and cleanness once per 5-10 months. The step is as follows:

1.Water side cleanness:

Guide the clean water with soft pipe to wash the in wall of the front and back cover and the surface of the heat-exchange pipe with high speed. And at the same time, scrub with detergent. After washing, dry it with compressed air.

2.Oil side cleanness

(1).Wash with chlorine there solution to make the cleaning solution circular flowing in the cooler with the pressure less than 0.6Mpa. The flow direction of the solution had better be adverse to that of the oil in the cooler. The leanness time defied is defied according to the condition of the dirt. Then pour water into the cooler to wash untill the water flow out is clean.

(2).Use the soak method and pour the solution into the cooler about after 15-20 minutes to see the color of the solution, if it is muddy, replace the so lution with new one to soak again until the it is clean. Then wash the cooler with water. (If wash with carbon tetrachloride, please operate at the environment with fine air to avoid of poisoning.)

(3).After wash, carry out hydraulic test or it can be replaced by 0.7Mpa gas pressure test. Then install it to the system to use.



(三) 常见故障及消除方法 TROUBLES AND SHOOTINGS

故障原因	Reasons	消除方法	Methods
换热性能下降 Heat-exchange function fal	冷却水量不足 The cooling water yield is not enough.	(1)开大进水阀 (2)检查管路、阀门、滤网、换热管是否被阻塞，如有应排除。	(1)Open the water inlet valve larger. (2)Check the pipeline, valve, filter net and heat-exchange pipe. if it is block or not. If it is, shoot it.
	换热管内或管间积气 The gas stores up inside or between the heat-exchange pipe.	拧下螺塞予以排气 Screw down the plug screw to exhaust the gas.	
	换热管内或管外表面积垢，流阻增大 The dirt store up inside or outside the heat-exchange pipe that result increasing the flowing resistance	消除换热管内外表面污垢 Remove the dirt inside or at the surface of the pipe.	
在回水盖(前盖)放水时，发现水和油混合现象 resistance increased. Find the water and oil mixed when drawing off the water return co(front cover).		(1)换热管破损引起泄漏时，用管塞堵死，但管子堵数不应超过总数的10% (2)换热管与管板密封不良，应予以焊补或胀紧牢。	(1)The heat-exchange pipe damage with will result in leakage. Block the leakage with pipe screw but the screw number should be no more than 10% of the total. (2)If the heat-exchange pipe and the pipe board are not well sealed. Weld it
法兰螺钉连接处发生泄漏 The outer joint of the flange screw is leakage.		(1)拧紧法兰上的紧固件和更换密封垫。 (2)冷却器一经拆装，尽可能使用新的密封垫	(1)Tighten the fixing part on the flange and replace the sealing gasket. (2)Once the cooler is disconnected, please use new sealing gasket.
固定管板和浮动管板以及换热管被腐蚀，造成冷却器失去密封性 The fixing board, the floating pipe boards and heat-exchange pipe is corroded that the cooler loses the sealing function		更换管束 Replace the pipe bundle.	

(四)标志、包装、运输

- 油冷却器出厂时附有出厂合格证，使用说明书
- 油冷却器应在壳体的显著部位固定一块标牌，牌上注明以下内容：
 - 注册商标
 - 产品名称
 - 产品型号
 - 冷却面积
 - 公称压力
 - 重量
 - 工作温度
 - 出厂编号
 - 制造厂名称
- 油冷却器包装，运输按JB/T7356-1994的规定进行。
- 油冷却器如确认有质量问题，本公司实行“三包”。

MARKS、PACKAGE AND TRANSPORTATION

- Oil cooler is enclosed with delivery leaving factory certification and operation manual in delivery.
- Fixing a label on the notable place of the oil cooler shell. In the label remark the followings:
 - registered trademark
 - product name
 - model
 - cooling area
 - nominal pressure
 - weight
 - woking temperature
 - leaving factory No.
 - Name of manufacturer
- Carry out the package and transportation of the oil cooler according to the provision JB/T7356-1994
- Our company has "three guarantees" for the oil cooler if it is de fined with quality defect.