



## NJU系列箱外内积式吸油过滤器

### NJU TANK MOUNTED SUCTION FILTER SERIES

#### (一) 简介

NJU系列箱外内积式吸油过滤器，具有连接方便、清洗或更换滤芯容易，易实现油箱封闭化，并设有组合法兰、旁通阀、污染积物盅、堵塞发讯器等装置。本产品经许多科研单位技术审查，经百家主机厂批量配套使用后证明，效果很好，并获国家专利局实用新型专利证书。

#### INTRODUCTION

The NJU-series filters are widely used in hydraulic systems. The filter can be installed on the top or at the side of the tank. The filter head should be out of tank and the filter bowl should be inserted from side or top of the tank into oil. The outlet is connected with pump outlet. 25~160 L/min type has combine removable flange, the working height can be adjusted in order to make the tank totally obdurate and that way can prevent the contamination from getting into the tank. During maintenance, open the filter cover, take out the filter element together with sludge cup and clean them. A by-pass valve and a vacuum are incorporated with the filter. When the pressure drop across the filter element reaches 0.018MPa, the indicator gives signals showing maintenance shall be done. If no service is done and as the pressure drop rises to 0.02MPa, the by-pass valve will open to ensure oil flow into pump.

#### (二) 技术性能

1、安装连接方便：本过滤器可安装在油箱盖板上上面或侧面，过滤器的滤头露于油箱外，吸油管从油箱上面或侧面插入油面，出油口与泵吸油口相连接，25~160 L/min规格设有组合活动法兰，连接高度可以上下调节，从而实现油箱全封闭，进一步防止污染物进入油箱。

2、清洗或更换滤芯方便：当滤芯需清洗或更换时，即可方便地打开过滤器上盖，取出滤芯及随同积污盅进行清洗或更换，清洗或更换后再放入，装好盖便可投入使用。

3、具有旁通阀：当滤芯被污染物堵塞到出油口真空度为0.018MPa时，发讯器便发出信号，应及时更换或清洗滤芯。若此时不能马上停机或无人来更换滤芯，设在滤芯上部的油路旁通阀会自动开启(开启压力：真空0.02MPa)，以避免油泵出现吸空等故障。

4、具有滤芯堵塞发讯器：本发讯器安装在过滤器的头盖上，当滤芯逐步堵塞时，可从发讯器的目测镜面上观察到过滤器的出口真空度及污染情况，同时还可接电发讯(发讯值：真空0.018MPa)。

5、具有积污盅：工作介质流经滤芯腔内将其中超过滤芯过滤精度的污染物阻挡在滤芯腔内，并集中在积污盅内。需清洗或更换滤芯时，积污盅随滤芯一同带出，滤除的污染物不会出现因更换滤芯时使污染物重新掉入油箱的现象。

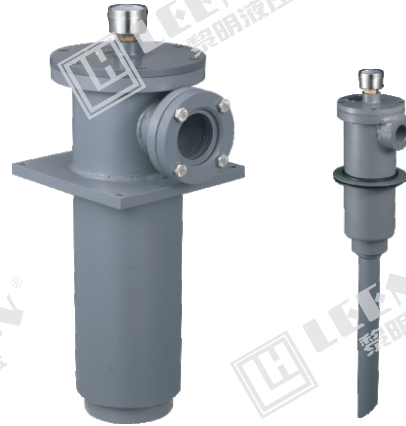
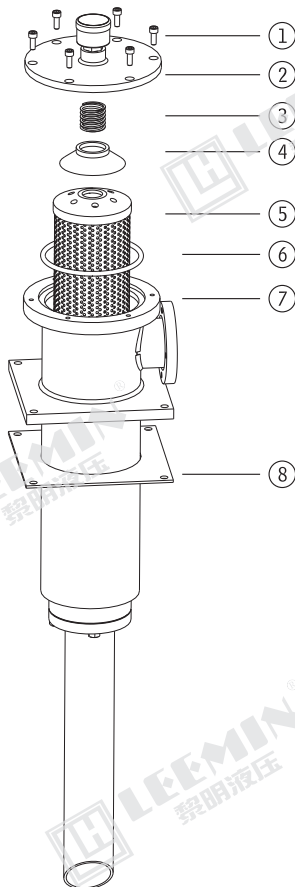

序号 Number	名称 Name	说明 Note
1	螺钉 Bolt	
2	滤盖 Cap	
3	弹簧 Spring	
4	弹簧座 Spring Seat	
5	滤芯 Element	易损件 Wearing Parts
6	O形密封圈 O-ring	易损件 Wearing Parts
7	壳体 Housing	
8	密封垫 Seal	易损件 Wearing Parts



### (三) 安装方法简图及型号说明 MOUNTING & MODEL CODE

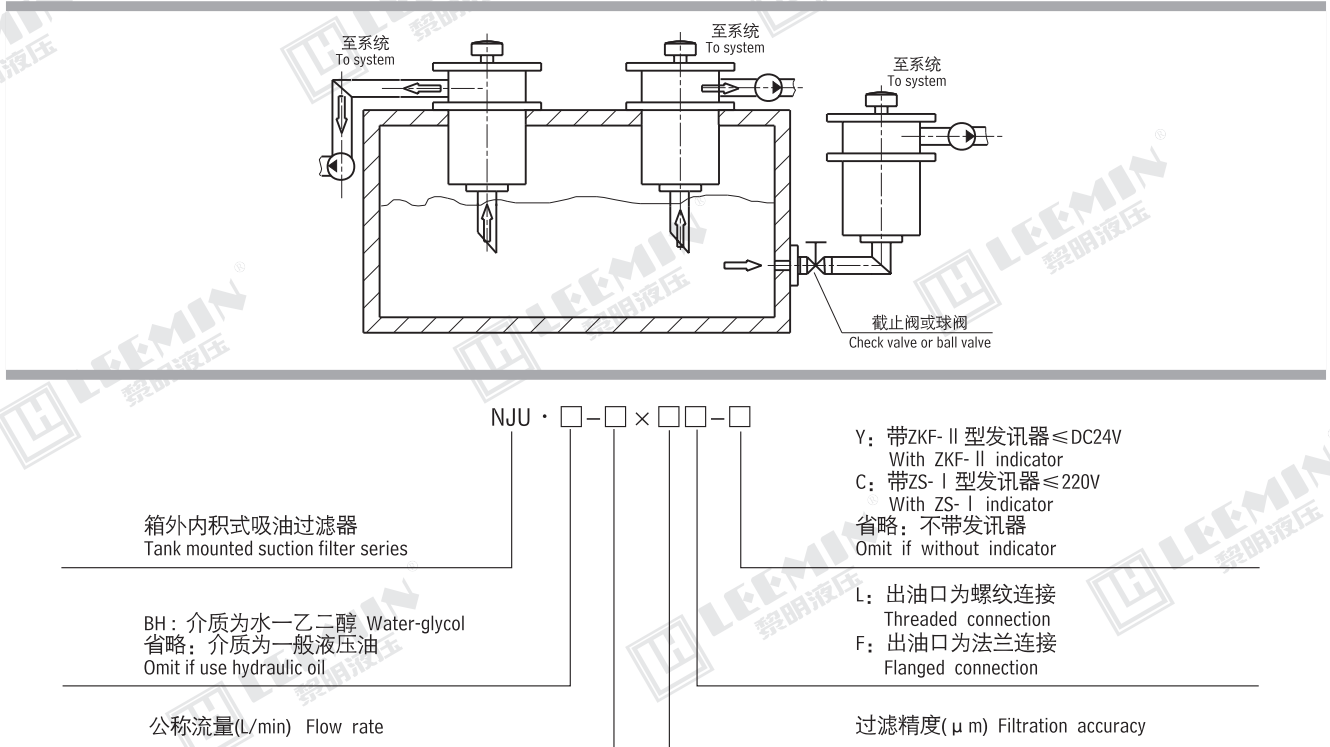

### (四) 技术参数及连接尺寸 TECHNICAL DATA AND MOUNTING SIZE

型号 Model	公称流量 Flow rate (L/min)	过滤精度 Filtr. (μm)	通 径 Dia. (mm)	原始压力损失 Initial ΔP (MPa)	发讯装置 Indicator		连接方式 Connecting	重 量 Weight (kg)	滤芯型号 Model of element
					(V)	(A)			
NJU - 25 × *L - C <sub>Y</sub>	25	80	15	< 0.007	12	2.5	管式 Thread	3.1	UX - 25 × *
NJU - 40 × *L - C <sub>Y</sub>	40		20						UX - 40 × *
NJU - 63 × *L - C <sub>Y</sub>	63		25						UX - 63 × *
NJU - 100 × *L - C <sub>Y</sub>	100		32						UX - 100 × *
NJU - 160 × *L - C <sub>Y</sub>	160		40						UX - 160 × *
NJU - 250 × *F - C <sub>Y</sub>	250	180	50	< 0.01	36	1.5	法兰 Flange	12.8	UX - 250 × *
NJU - 400 × *F - C <sub>Y</sub>	400		60						UX - 400 × *
NJU - 630 × *F - C <sub>Y</sub>	630		80						UX - 630 × *
NJU - 800 × *F - C <sub>Y</sub>	800		90						UX - 800 × *

注: \*为过滤精度, 若使用介质为水—乙二醇, 公称流量160L/min, 过滤精度80 μm, 带ZS-I型发讯器, 则过滤器型号为NJU · BH-160 × 80L - C, 滤芯型号为UX · BH-160 × 80。

Note: \*is filtration accuracy, If the medium is water-glycol, flow rate is 160L/min, filtration accuracy is 80 μm, with ZS-I indicator, the model of this filter is NJU · BH-160 × 80L-C, the model of element is UX · BH-160 × 80.



**LEEMIN**  
黎明液压

1、NJU-25~160型(对照表一)(Table 1.)

2、NJU-250~800型(对照表二)(Table 2.)

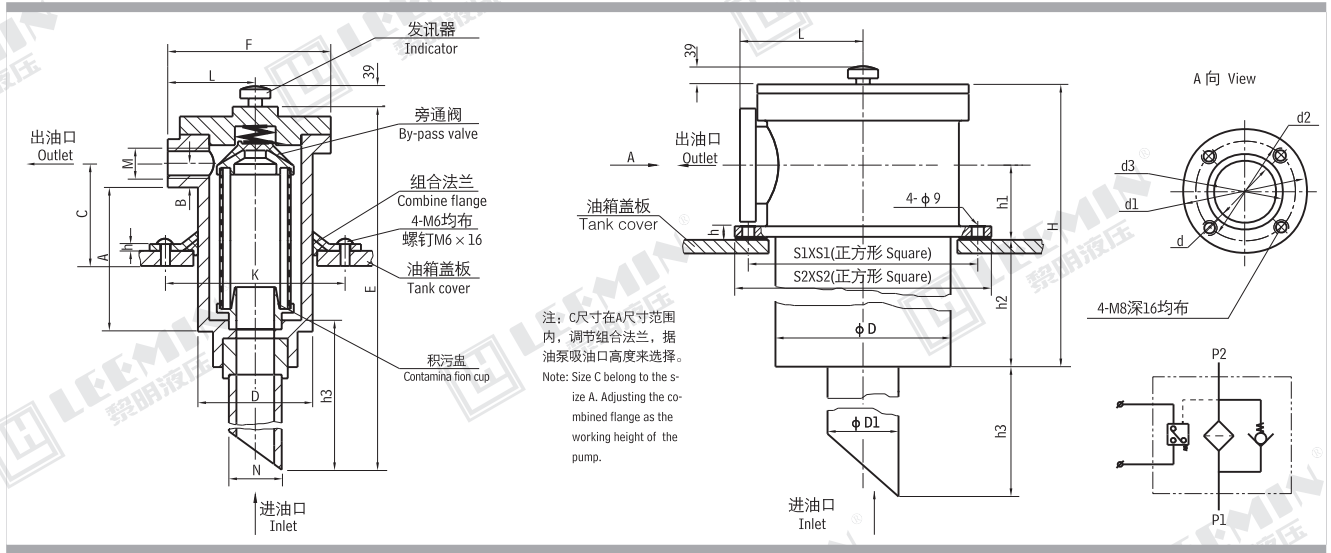

表一：NJU-25~160螺纹连接参数 Table 1: NJU-25~160 Threaded Connection

单位 Unit:mm

型号 Model	出油口螺纹 Thread M	A	B	h3	E	F	L	D	K	N	h
NJU-25 × *L - C <sub>Y</sub>	M22 × 1.5	123	23	255	453	102	53	φ 72	φ 95	φ 25	6
NJU-40 × *L - C <sub>Y</sub>	M27 × 2	153	23		482						
NJU-63 × *L - C <sub>Y</sub>	M33 × 2	174	28	385	637	122	65	φ 89	φ 115	φ 38	6
NJU-100 × *L - C <sub>Y</sub>	M42 × 2	212	33		687						
NJU-160 × *L - C <sub>Y</sub>	M48 × 2	257	35		737						

表二：NJU-250~800法兰连接参数 Table 2: NJU-250~800 Flanged Connection

单位 Unit:mm

型号 Model	d	d1	d2	d3	D	S1	S2	h1	h2	h3	H	D1	L	h
NJU-250 × *F - C <sub>Y</sub>	50	100	84	60	122	160	180	67	256	402	392	60	98	16
NJU-400 × *F - C <sub>Y</sub>	60	115	99	70	142	180	200	75	271	407	419	70	110	16
NJU-630 × *F - C <sub>Y</sub>	80	130	114	90	162	200	220	82	279	517	440	90	120	16
NJU-800 × *F - C <sub>Y</sub>	90	140	124	104	182	240	260	90	289	534	466	102	131.5	16

注：该产品所需的出油口法兰、密封圈、螺钉、吸油管均由我公司提供，用户只需准备d3管子焊上即可。

Note: The outlet flange, seal, screw and suction tube used for this series will be supplied by our plant. The customer only need welding the steel tube d3.